



# Industrial & Commercial Building Solutions





# INDEX

About Solution .....	5
Topology .....	10
Products .....	11
Certificates .....	62
Panel Devices .....	63
References .....	64





EAE KNX Commercial and Industrial Building Solutions is flexible and expandable to meet all the requirements and expectations of users.

EAE's Smart Solutions are developed for energy savings with a strong focus on innovation, functionality and design.

Products are based on the worldwide KNX standard and enable the system to be expanded with other KNX manufactured products.

EAE products were used in these projects.

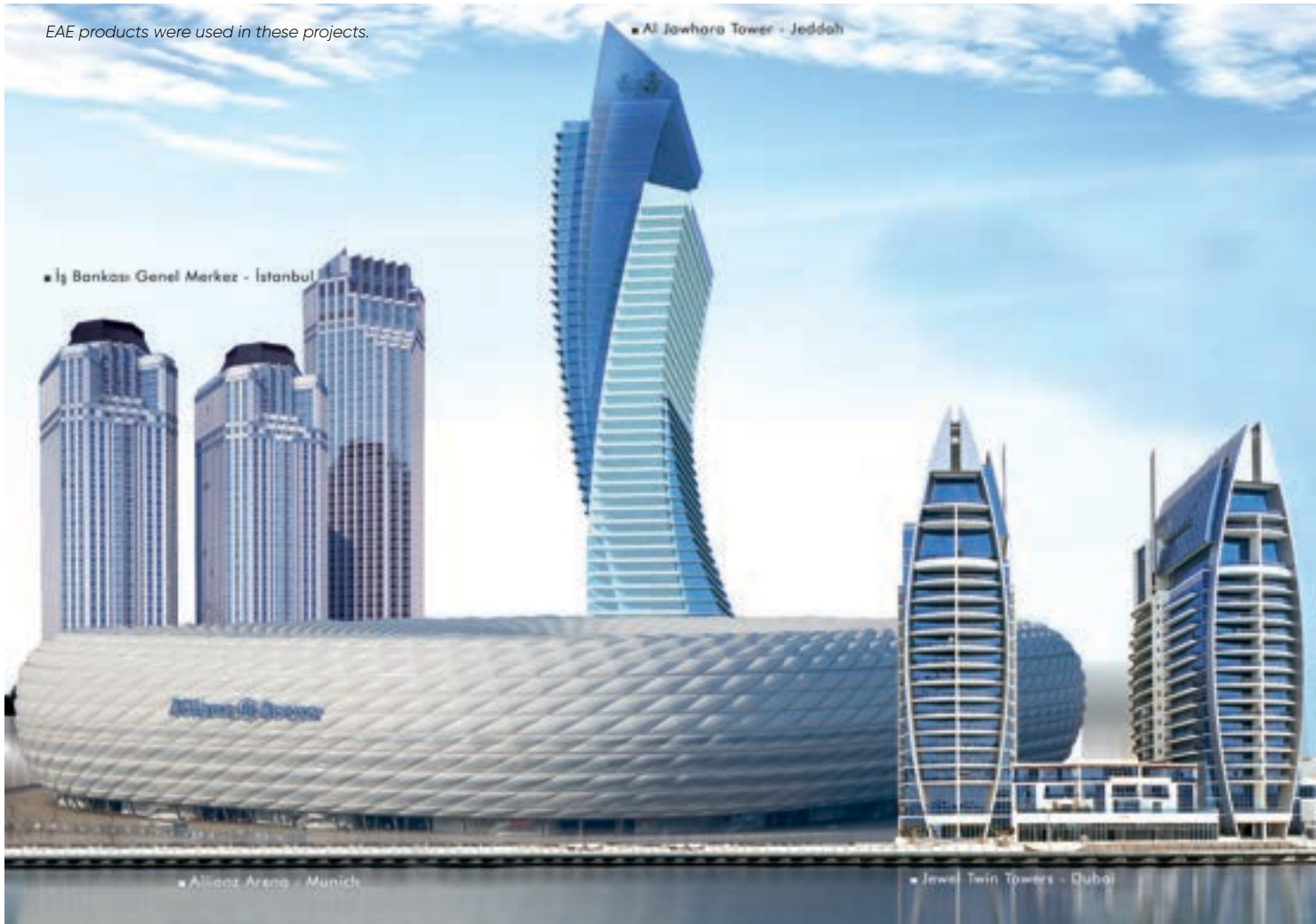

1973  
Establishment date

290.000 m2  
Production area

Products used in  
100+ Countries



More than 2,500  
Employees

6  
Factory

EAE group of companies have over 2,500 employees worldwide and EAE products are used in more than 100 countries. EAE Group has over 50 patents, 300 brands and 150 industrial designs.



KNX Member & Training Center

1.000.000+ Active device in the world

Design, Production In Istanbul - Turkey

KNX



80+ Export Countries

50+ Expert Technical Team

As EAE Technology, we provide innovative and value-added solutions for KNX applications. All our products are designed, developed, manufactured and tested in our headquarters in Istanbul, Turkey. EAE Technology products are in compliance with international open standards such as KNX, DALI, TCP/IP and WiFi.

EAE Technology is a member of KNX Association and an authorized KNX training center since 2012.

## Movement and Daylight Sensor Control

The lighting and air conditioning devices are controlled by means of sensors sensitive to movement.

## Timing, Schedule Management

Automatic control of devices is ensured by means of daily, weekly monthly or custom developed schedules.

## Daylight Harvesting

Both indoor and outdoor lighting requirements can be managed by means of daylight related controls.

## Zone Control On/Off & Dim

Standard lighting fixtures can now be managed in line/group basis by means of switching modules.

## HVAC Control: VRF, VRV, Fancoil, Air Conditioning etc...

Heating/cooling monitoring and management is in your hands thanks to the fancoil control units.







### Central Monitoring / Control

The monitoring and control functions are managed centrally in a convenient manner and with speed over architectural visuals.

### DALI Lighting Control

You can monitor and manage your lighting fixtures of dimmable and addressable nature.

### Shutter-Blind Control

You can control your curtains/blinds and/or sunshades according to the daylight, time of the day over a central monitoring system.

### Emergency Lighting Reporting

Reports the battery testing and error status of the emergency lighting fixtures available in the facility.

### Alarm & Warning Reports

Provides instant warnings over SMS and e-mail and saves time in special situations where the establishment is required to respond promptly.



Ref. ISTANBUL AIRPORT THY BUILDINGS

# TOPOLOGY

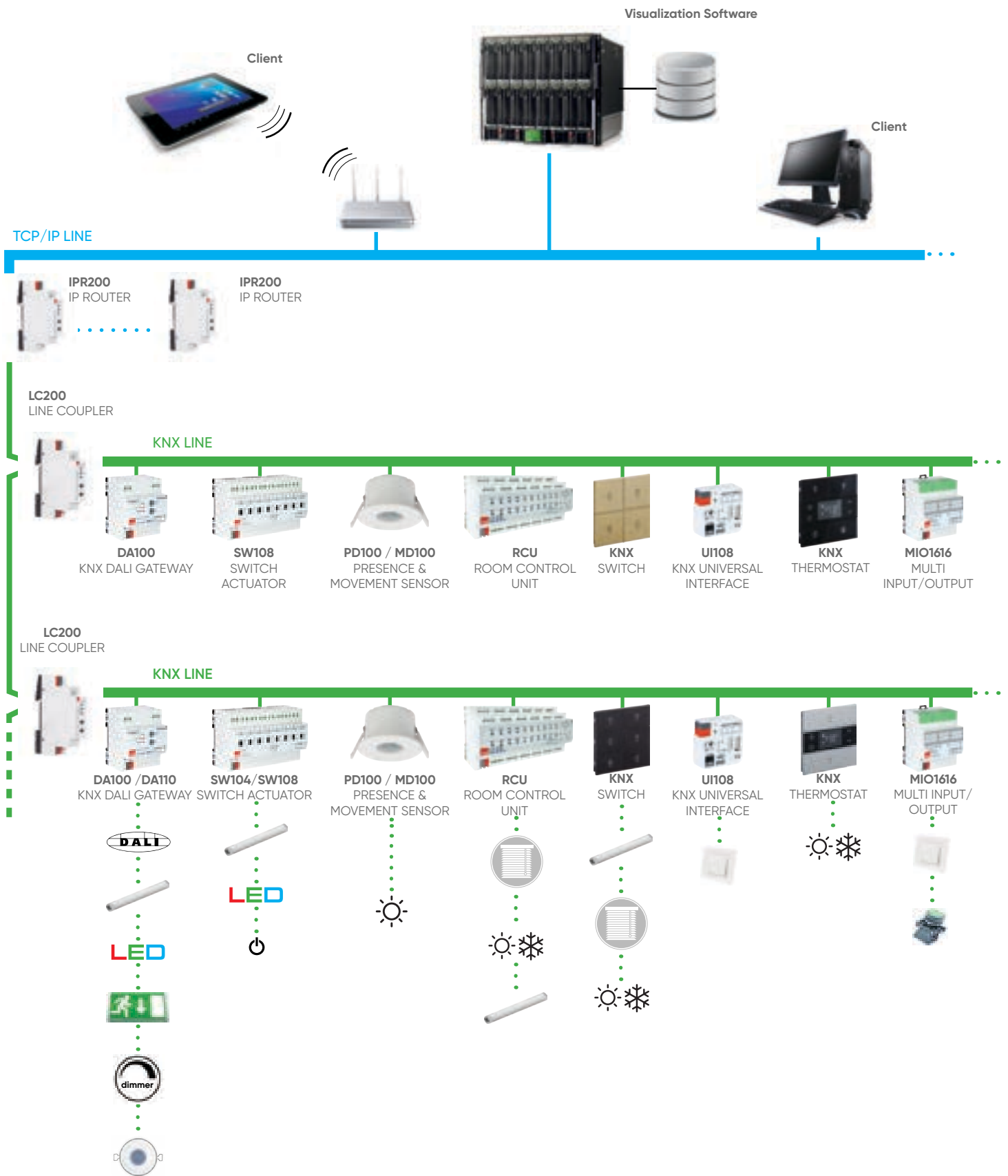

▶ Miola Touch Panel 7.0"



▶ Miola Touch Panel 10.1"



▶ Thermostat & Switches

mona



rosa metal



rosa crystal



oria



▶ Panel Devices



## PRODUCTS

- ▶ **MIOLA TOUCH PANEL**
- ▶ **PD100 / MD100** PRESENCE AND MOVEMENT SENSOR
- ▶ **CD100** CORRIDOR DETECTOR
- ▶ **HB360** HIGHBAY MOTION DETECTOR
- ▶ **RCU2018 / RCU2000 / RCU1616 / RCU1600 / RCU1212 / RCU1200 / RCU0808 / RCU0800** ROOM CONTROL UNIT
- ▶ **SW104 / SW108** SWITCH ACTUATOR
- ▶ **DA100 / DA110** KNX DALI GATEWAY
- ▶ **UD106** UNIVERSAL DIMMER
- ▶ **SD110** 0-10V / 1-10V DIM ACTUATOR
- ▶ **FCA100** FANCOIL ACTUATOR
- ▶ **PSU320/640** POWER SUPPLY
- ▶ **KMG103** KNX MODBUS GATEWAY
- ▶ **UI108** KNX UNIVERSAL INTERFACE MODULE
- ▶ **MIO1616** MULTI INPUT / OUTPUT
- ▶ **IPR200/ IPR200S** KNX IP ROUTER / SECURE
- ▶ **IPI200 / IPI200S** KNX IP INTERFACE / SECURE
- ▶ **LC200/LC200S** KNX LINE COUPLER / SECURE
- ▶ **KNX SWITCHES, THERMOSTATS and FRAMES**





**With Miola Panel, you can easily control your home!**

You will be able to receive all the notifications you specify and want to receive from the mobile application, and you will be able to easily learn all the details you follow with the push-notification feature.

Thanks to the Cloud server, you will not need an extra server!



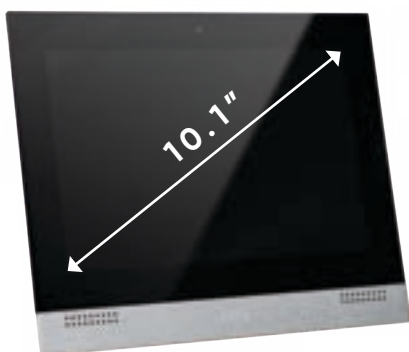

10.1" MIOLA



7" MIOLA

**Color Options**



Natural



Grey



Black

**Lath Options**



Metal



Plastic



Plastic/Metal

**Miola Technical Data**

SCREEN SIZE	7" MIOLA KNX-TP	10.1" MIOLA KNX-TP
CPU	PX30 Chipset	PX30 Chipset
Memory	1GB	1GB
Hard Disk	8GB EMMC	8GB EMMC
Operating System	Android 8.0	Android 8.0
Power	12-30 VDC	12-30 VDC
Resolution	600x1024px	1280x800px
Touch Panel	Project Capacitive Touch	Project Capacitive Touch
Microphone	1 with Echo Cancellation	1 with Echo Cancellation
Speaker	1x8 Ohm - 2 Watts	1x8 Ohm - 2 Watts
Input	5 Digital Inputs	5 Digital Inputs
KNX Bus Connection	KNX - TP	KNX - TP
LAN	2	2
Dual Network Connection	Yes	Yes
Drives	EAEOS Operating System Drivers	EAEOS Operating System Drivers
Max Accessory Limit	254	254
Max Room Limit	254	254
Intercom Standart	SIP 2.0	SIP 2.0
Onwall Dimensions	140 x 235 x 4 mm	140 x 235 x 4 mm

\* High voltage and overcurrent protection, insulated

# PD100 / MD100

## EAE KNX SENSOR

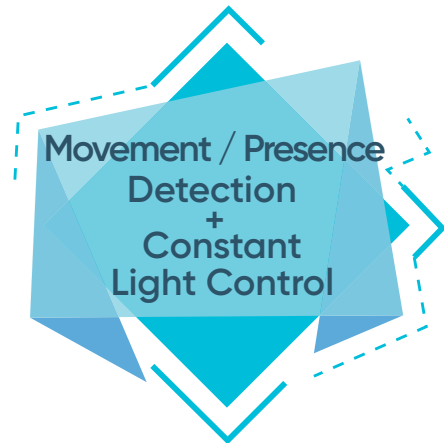

### General Specifications

- PD100 movement sensor is ideal for indoor use such as in medium and large scale office spaces, conference halls, corridors, classrooms, parking garages. It comes in two models; **flush-mounted and surface-mounted**.

- Thanks to the integrated light level sensor and movement sensor it can implement fixed light function depending on the presence of a movement. The current level of ambient light is compared to the lux level desired to ensure the appropriate level of illumination in the area concerned.

- By means of the corridor function, different levels of brightness can be arranged for the states of; "Movement", "After Movement", and "No Movement". The duration of light projection after the movement can be adjusted by the user.

- Other than the control of the lighting level, it would also be possible to control the air conditioning and ventilation through HVAC.

- It is possible to send periodic information of different communication object by means of the independent movement monitoring channel. This could be used in movement monitoring applications.

- It can operate in parallel connection with other sensors either on standalone or master-slave basis depending on application requirements.

- Based on the state of use of the external controls (button, switch, other sensors, etc.) full or semi automatic operating modes could be set-up.

- Test and calibration modes are convenient during installation.

- Does not need external power supply as it receives its power supply over KNX line

### Dimensions (mm)

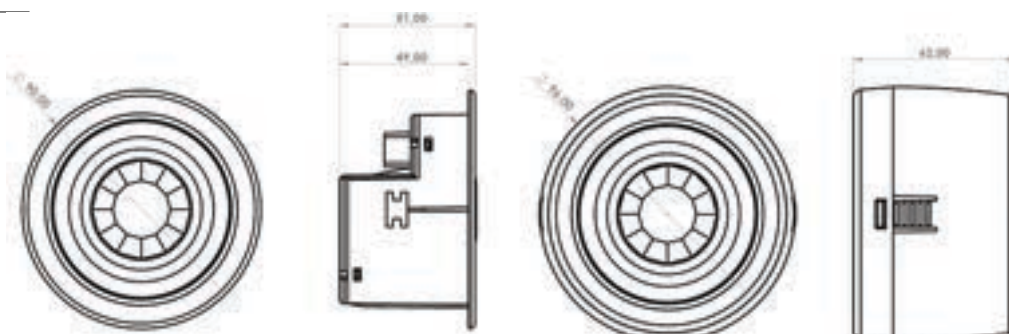

**Technical Information**

<b>Protection Type</b>	IP 20 / IP 44 (Surface Mounted)	EN 60529
<b>Safety Class</b>	II	EN 61140
<b>Power Supply</b>	Voltage range Current consumption	21 - 30V DC, KNX Line < 10mA
<b>Application areas</b>		Indoors
<b>Sensor Type</b>		Passive infrared
<b>Installation</b>	Location Recommended height	Ceiling 2.5 m – 5.5m
<b>Detection</b>	PD100 Diameter (at 2.5 m height) MD100 Diameter (at 2.5 m height) Angle Light Level	6 m diameter (tangent walk) 9 m diameter (tangent walk) 360 1 – 1000 lux
<b>Additional Channels</b>		Illumination level, movement channel, HVAC ch.
<b>Parallel Operation</b>		Master/Master, Slave/Master
<b>Operating Elements</b>	LED (Red) and button	Used to program the device
<b>Temperature Range</b>	Operation Storage	- 5°C +45°C -25°C +55°C
<b>Dimensions</b>		42.5 x 42,5 x 12 mm
<b>Weight</b>	0.06 kg	
<b>Ceiling section dimension</b>	75 mm diameter	

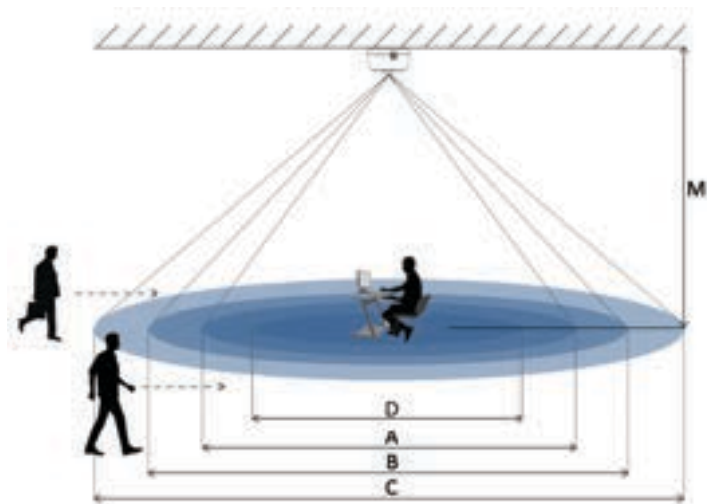

A: Area of detection according to a seated person  
 B: Area of detection upon direct approach on feet  
 C: Area of detection upon tangent approach on feet  
 D: Area of the brightness measuring in working desk height

**PD100 Presence Sensor**

PD100	A	B	C	D
4,0 m	7,8 m	7 m	12 m	Ø2.3
3,5 m	7,3 m	6,5 m	10 m	Ø2.0
3,0 m	6 m	6 m	8 m	Ø1.6
2,5 m	5 m	5 m	6 m	Ø1.2

**MD100 Movement Sensor**

MD100	B	C	D
5,5 m	12 m	18 m	Ø3.3
5,0 m	9 m	15 m	Ø3.0
4,0 m	8 m	13 m	Ø2.3
3,5 m	7,5 m	12 m	Ø2.0
3,0 m	7 m	10,5 m	Ø1.6
2,5 m	6,5 m	9 m	Ø1.2

**Ordering Information**

Product Name	Product Code	Ordering Code	Package Information
EAE KNX Presence Sensor (Flush mounted)	SMP PD100 EAE F-KNX	48083	1 pcs.
EAE KNX Movement Sensor (Flush mounted)	SMP MD100 EAE F-KNX	48084	1 pcs.

# CD100

## EAE KNX CORRIDOR SENSOR



### General Specifications

- The CD100 KNX Corridor Sensor is developed for corridors, warehouses and car parking spaces. It has two mounting options which are flush mounted and surface mounted (recommended max. height 4.5m).
- Depending on the entity, a constant light function can be applied with the integrated brightness and motion sensor. The existing light may be compared with the desired level of light and an adequate level will be provided.
- The sensor has corridor function feature. Through to this feature presence, absence, stay on time and switch off delay values can be adjustable via KNX (Corridor function graph).
- It can operate in parallel connection with other sensors either on standalone or master-slave basis depending on application requirements.
- Based on the state of use of the external controls (button, switch, other sensors, etc.) full or semi automatic operating modes could be set-up.
- Test and calibration modes are convenient during installation.
- Does not need for external supply. It receives its power over KNX line.

### Corridor function graph

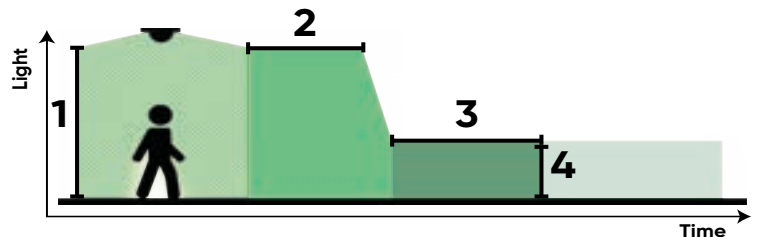

- 1 Presence value** : Luminous intensity set for the presence of persons
- 2 Stay on time** : Delay time
- 3 Switch off delay** : Period of time during which the absence value is maintained before the lighting is switched off.
- 4 Absence value** : Luminous intensity set for the absence of persons

### Dimensions (mm)

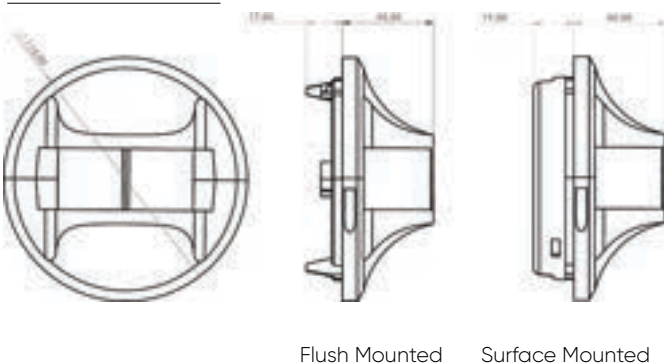



Technical Information

Protection Type	IP 20 / IP 44 (Surface Mounted) IP 20 (Recessed)	EN 60529
Safety Class	II	EN 61140
Power Supply	Voltage range Current consumption	21 - 30V DC, KNX line < 10mA
Application areas	Indoors, Corridors, Car parks, Warehouses	
Sensor Type	Passive infrared	
Installation	Location Recommended height	Flush / Surface Mounted 2.5 m – 4.5 m
Detection	CD100 Coverage (at 3 m height) Angle Light Level	12x4 m coverage (radial walk) 20x6 m coverage (tangent walk) 180° aisle 1 – 1000 lux
Additional Channels	Illumination level, movement channel, HVAC	
Parallel Operation	ch. Master/Master, Master/Slave	
Operating Elements	LED (Red) and button	Used to program the device
Temperature Range	Operation Storage	- 5°C +45°C -25°C +55°C
Dimensions	Flush Mounted; (H) = 60 mm x (Ø) = 115 mm Surface Mounted; (H) = 62 mm x (Ø) = 115 mm	
Weight	Flush Mounted; 83g Surface Mounted; 97 gr	
Ceiling section dimension	Ø 102 mm (4inch)	

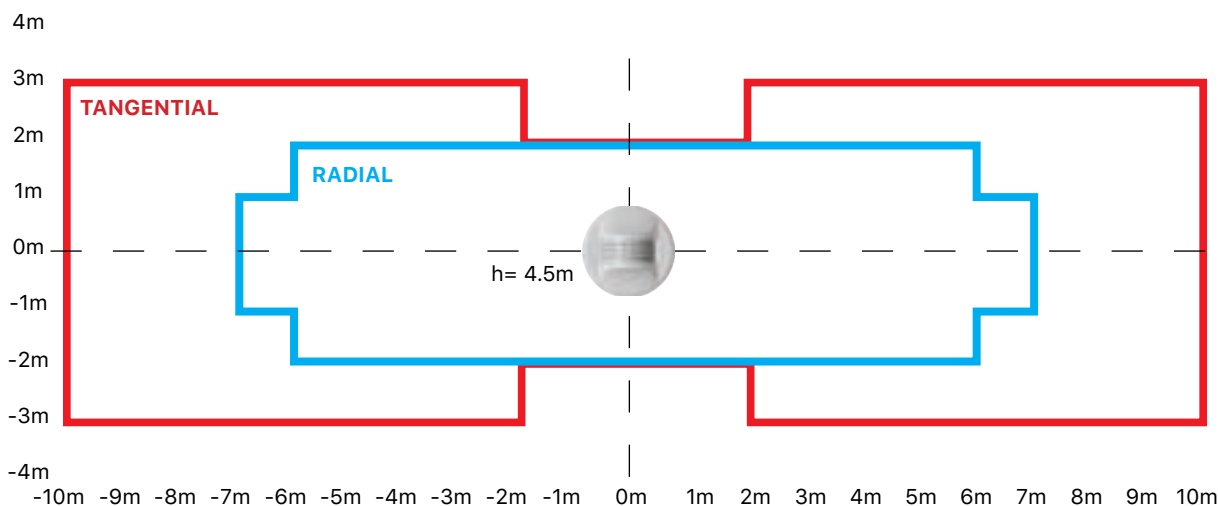
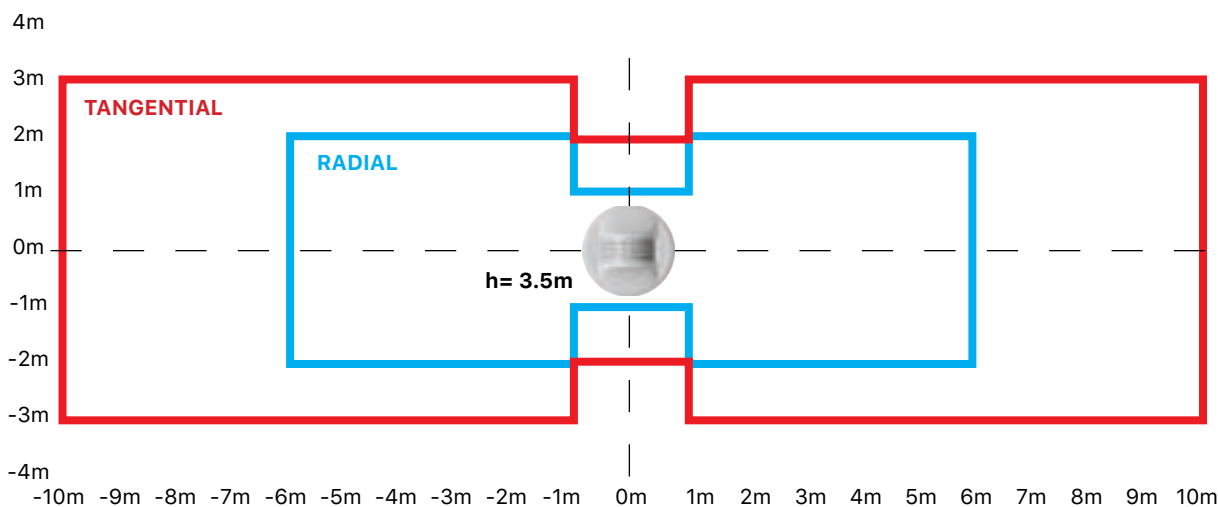

# HB360

## EAE KNX Highbay Motion Sensor

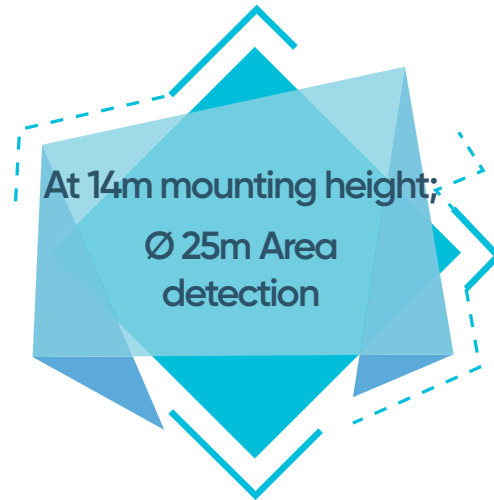

### General Specifications

- HB360 KNX Highbay Motion Detector is ideal for warehouses, industrial areas, conference rooms and sport halls.
- Constant light function can be applied in dependence of presence information thanks to integrated brightness sensor and movement sensor. HB360 regulates the ambient brightness to a defined brightness value.
- Lighting can be set to different brightness levels with corridor function based on occasions such as "movement, after movement, no movement". Stay-on time can be changed the by end user...
- Air-conditioning and ventilation systems can be controlled by independent HVAC channel.
- Presence information can be sent to presence monitoring applications by independent presence channel.
- The EAE KNX HB360 can be used as a standalone device or master-slave device (parallel operation with other sensors) according to necessity of project.
- HB360 enables fully-automatic and semi-automatic lighting control.
- Test and calibration mode allow for easy installation.
- The device does not require an additional power supply.

### Dimensions (mm)

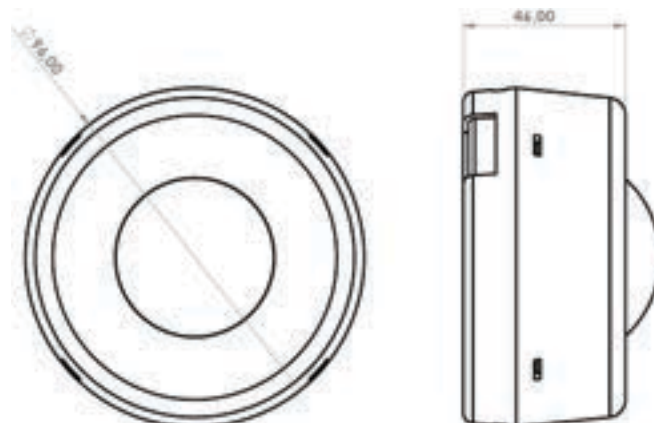

Technical Information

Protection Type	IP 20 / IP 44	EN 60529
Safety Class	II	EN 61140
Power Supply	Voltage Current consumption	21 - 30V DC, KNX Line < 10mA
Application areas		Warehouses, Car Parks etc.
Sensor Type		Passive infrared
Installation	Location	Ceiling
Detection	Diameter (at height of 12m) Area Angle Light Level	14m movement detection Ø 25 m 360° 1 -1000 lux
Additional Channels		Brightness, presence channel, HVAC channel
Parallel Operation		Master/Master, Slave/Master
Operating Elements	LED (red) and button	For physical address
Temperature Range	Operation Storage	- 5°C +45°C -25°C +55°C
Dimensions		See Scale Drawings
Weight	0.065 kg	
Box	Plastic, polycarbonate, white	
CE	In accordance with the EMC guideline and low voltage	

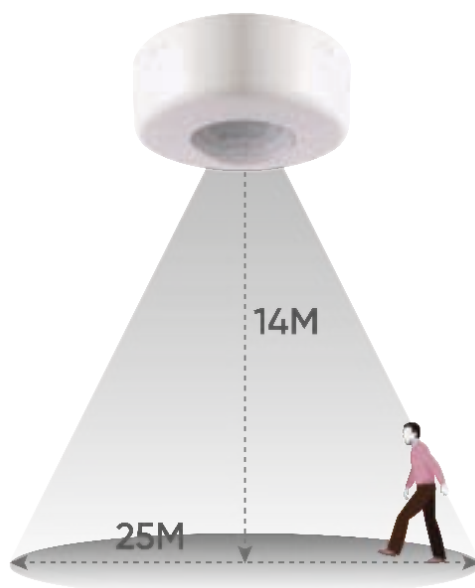

Ordering Information

Product Name	Product Code	Ordering Code	Package Information
EAE KNX Highbay Motion Detector (Surface mounted)	SMP HB360 EAE F-KNX	48108	1 pcs.



# RCU2018

RCU2018 / RCU2000 / RCU1616 / RCU1600  
RCU1212 / RCU1200 / RCU0808 / RCU 0800

## EAE KNX-ROOM CONTROL UNIT



**20x16A Outputs  
+  
18 Inputs**

### General Specifications

- Room Control Unit RCU2018 is designed as an all in one product for different room layouts such as apartments, hotel rooms, hospitals and residences.

- Room Control Unit covers all requirements of the electrical installation of room applications and offers following functions in a one product.

- Switching lighting
- Switching loads
- Controlling AC/DC blinds
- Controlling fan coils (2 & 3 point valve)
- Dry contact inputs

- RCU2018 has 20x16A relay outputs. These outputs are grouped as 5 independent output channels. Each channel can be configured to have different modes of operation as follows,

- Switching output x4
- AC Blind x2
- DC Blind x1
- 2 Point valve x2
- 3 point valve x2

- Suitable for switching resistive, capacitive and inductive loads as well as fluorescent lamp loads according to EN 60669. As a switch output device provides following function list,

- Staircase
- External logic
- Internal logic
- Priority
- Threshold
- Operating hour
- Sweep

- Device has 18 independent input channels. Input channel operates as universal interface with following functions,

- Switch / push button input
- Dimmer control
- Control of shutter/blinds
- Value sending
- Scene control
- Counter for count pulse

- Manual control is possible for each channel through the built-in button panel.

- 220V auxiliary power is not required.

Dimensions (mm) RCU2018 RCU1616 RCU1600 RCU2000

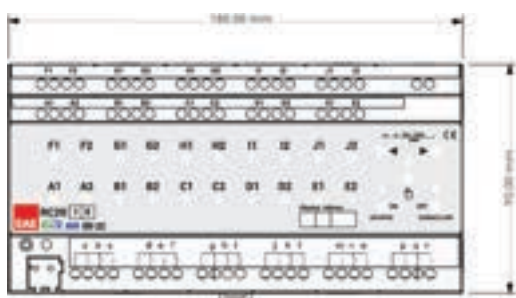

Dimensions (mm) RCU1212 RCU1200 RCU0808 RCU0800

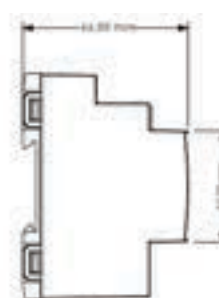
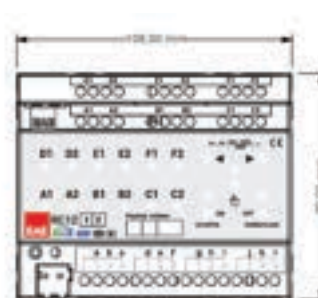
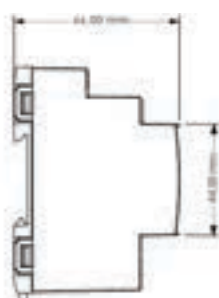

**Technical Information**

<b>Protection Type</b>	IP 20	EN 60529	
<b>Safety Class</b>	II	EN 61140	
<b>Power supply</b>	Voltage	21V... 30V DC, SELV	
	Current consumption	< 15 mA	
<b>External supply</b>	-	-	
<b>Connections</b>	Screw terminals	0,05...4 mm solid and stranded wire 0,05...2,5 mm stranded wire with ferrule	
	Max tightening torque KNX	0.8 Nm Bus connect terminal	
<b>Output</b>	Quantity	20 output (RCU2018, RCU2000)	
	Switching ratings	16A 250VAC / $6 \times 10^3$ OPS (Resistive) 3500W 277VAC / $1.2 \times 10^4$ OPS (Incandescent lamp)	
	Max. Inrush current	492A/1.5ms - 165A/20ms	
	Maximum switching power Mechanical life	4000VA $2 \times 10^6$	
<b>Type of contact</b>	potential-free, bistable		
<b>Input</b>	Quantity	18 binary inputs	
	Scanning voltage	32V pulsed	
	Current	0.1 mA	
	Cable length	<300 m	
<b>Installation</b>	35 mm mounting rail	EN 60715	
<b>Operating elements</b>	LED (red) and button	For physical address	
<b>Temperature range</b>	Operation	-5° C + 45° C	
	Storage	-25° C + 55° C	
<b>Dimensions</b>	H x W x D	90 mm x W x 66 mm	90 mm x W x 66 mm
	Width W (mm)	180 mm	108 mm
	Width W (unit)	10x18 mm modules	6x18 mm modules
<b>Weight</b>	0.65 kg		
<b>Box</b>	Plastic, polycarbonate, grey		
<b>CE</b>	In accordance with the EMC guideline and low voltage		

**Ordering Information**

Product Name	Product Code	Ordering Code	Package Information
EAE-KNX Room Control Unit 20ch, 18Input, Fancoil, Switch, Blind actuator	SMP RCU2018 EAE S-KNX	48024	1 unit
EAE-KNX Room Control Unit 20ch, Fancoil, Switch, Blind actuator	SMP RCU2000 EAE S-KNX	48027	1 unit
EAE-KNX Room Control Unit 16ch, 16 Input Fancoil, Switch, Blind actuator	SMP RCU1616 EAE S-KNX	48029	1 unit
EAE-KNX Room Control Unit 16ch, Fancoil, Switch, Blind actuator	SMP RCU1600 EAE S-KNX	48028	1 unit
EAE-KNX Room Control Unit 12ch, 12 Input, Fancoil, Switch, Blind actuator	SMP RCU1212 EAE S-KNX	48130	1 unit
EAE-KNX Room Control Unit 12ch, Fancoil, Switch, Blind actuator	SMP RCU1200 EAE S-KNX	48129	1 unit
EAE-KNX Room Control Unit 8ch,8 Input Fancoil, Switch, Blind actuator	SMP RCU0808 EAE S-KNX	48128	1 unit
EAE-KNX Room Control Unit 8ch, Fancoil, Switch, Blind actuator	SMP RCU0800 EAE S-KNX	48127	1 unit

# SW104/SW108

## EAE KNX SWITCH ACTUATOR

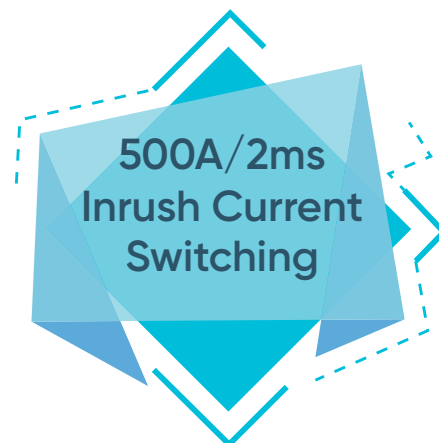

### General Specifications

- Possesses 4 and 8 independent channels that could be configured by means of ETS5 or higher.

- In addition to switching fluorescent lamps according to EN 60669 standard it can also perform the switching of resistive and inductive loads. (16A-20AX/C-Load).

- Each channel can be controlled manually on the device.

- The following functions can be defined separately for each channel:

- Stair function
- External logic
- Internal logic
- Priority function
- Threshold function
- Transaction time
- Sweeping function.

- Does not need an external power supply

- The current on/off situations can be arranged by means of ETS parameters.

### Dimensions (mm):

SW108 Dimensios

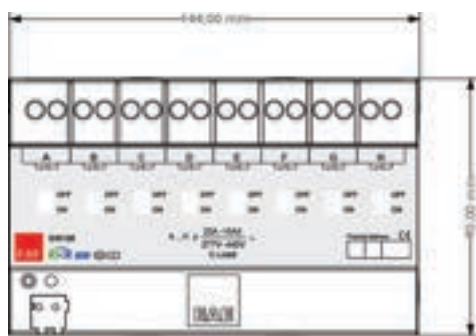

SW104 Dimensios



**Technical Information**

<b>Protection Type</b>	IP 20	EN 60529
<b>Safety Class</b>	II	EN 61140
<b>Power Supply</b>	Voltage Current consumption	21 - 30V DC, SELV < 10mA
<b>Connections</b>	Screw  Maximum Torque KNX	0,05 - 2,5 mm <sup>2</sup> 0,03 - 1,5 mm <sup>2</sup> high 0.8 Nm Bus connect terminal
<b>Output</b>	Quantity of output units Switching Ratings  Max. Inrush Current Max. Switching power	SW104 (4 channels) ; SW108 (8 channels) 50A 277VAC / 1x10 <sup>6</sup> OPS (Resistive) 5000W 240VAC / 3x10 <sup>4</sup> OPS (Incandescent lamp) 16A 277VAC / 6x10 <sup>3</sup> OPS (Electronic ballast) 5HP 277VAC / 3x10 <sup>4</sup> OPS (Motor) 500A/2ms 12500VA
<b>Relay</b>	Mechanic Life	1 x 10 <sup>6</sup>
<b>Contact type</b>	Bistable, dry contact	
<b>Configuration</b>	35 mm mounting rail	EN 60715
<b>Operating Elements</b>	LED (Red) and button	Used for physical address
<b>Temperature Range</b>	Operation Storage	- 5°C +45°C -25°C +55°C
<b>Dimensions</b>	H x W x D Width W (mm) Width W (unit)	90 mm x W x 66 mm 144 mm 8x18 mm modules 90 mm x W x 66 mm 72 mm 4x18 mm modules
<b>Weight</b>	0,45 kg / 0,24 kg	
<b>Box</b>	Plastic, polycarbonate, grey	
<b>CE</b>	Pursuant to EMC Guide and Low Current Regulation	

**Ordering Information**

Product Name	Product Code	Ordering Code	Package Information
EAE Switch Actuator 4x16A	SMP SW104 EAE S-KNX	48037	1 unit
EAE Switch Actuator 8x16A	SMP SW108 EAE S-KNX	48002	1 unit

# DA100

## EAE KNX-DALI GATEWAY (16 Group Control)



### General Specifications

- Device parameters can be configured via ETS5 or higher.
- DA100 KNX-DALI interface operates as a DALI-IEC 62386 standard compliant gateway between KNX line and DALI. DALI line power supply is available as integrated to the device.
- Maximum of 64 DALI devices can be connected to DALI output(electronic ballast, LED drive).
- The operations such as addressing, grouping, etc. of DALI devices are performed by means of Windows based DALI commissioning software (EAE DALI Commissioning Tool).
- DA100 provides the means for the recording of 16 DALI Group controls and 64 different lighting scenes.
- Each DALI group could be operated with fixed light, corridor and sequence functions.
- The functional and battery testing calendars are loaded on to DALI compliant emergency lighting fixtures to ensure that periodic tests are conducted. The results of the tests conducted are relayed over KNX line.
- The error status of DALI devices can be received by means of different KNX communication objects on device and group basis.
- Intersecting DALI groups can be created.

### Dimensions (mm)

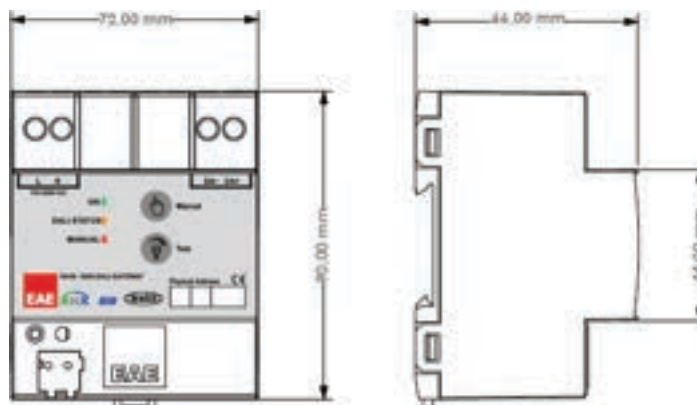



**Technical Information**

<b>Protection Type</b>	IP 20	EN 60529
<b>Safety Class</b>	II	EN 61140
<b>KNX Power Supply</b>	Voltage range Current consumption	21 - 30V DC, SELV < 10mA
<b>External Power Supply</b>	Voltage range Power Consumption Current consumption	85 - 300V AC @ 50-60Hz ≤ 8W 100mA @ 85V AC
<b>DALI Power Supply</b>	Voltage range Current consumption	16V DC ~ ≤ 200mA
<b>Connections</b>	Screw terminal  Maximum Torque KNX Terminal	0,05 - 2,5mm <sup>2</sup> single core cable 0,03 - 1,5mm <sup>2</sup> multi core cable 0.5Nm Red-Black KNX Line Connection
<b>Output</b>	Quantity of DALI devices Cable lengths	Maximum 64 (max. 8 sensors) 1.5 mm <sup>2</sup> ≤ 300 m 0.75 mm <sup>2</sup> ≤ 150 m 0.5 mm <sup>2</sup> ≤ 100 m
<b>Configuration</b>	35 mm mounting rail	EN 60715
<b>Operating Elements</b>	Programming LED and button Green LED <sup>(7)</sup> Yellow LED <sup>(8)</sup>  Red LED <sup>(9)</sup> Manual Button <sup>(10)</sup> Test Button <sup>(11)</sup>	Used for physical address Problem-free KNX line First start-up (fast flashing) Device failure on DALI Line (slow flashing) Power supply fault (continuously on) Manual control active Entire DALI line on-off, dimming (when manual control is active)
<b>Temperature Range</b>	Operation Storage	-5°C +45°C -25°C +55°C
<b>Dimensions</b>	H x W x D Width W (mm) Width W (unit)	90 mm x W x 66 mm 72 mm 4x18 mm modules
<b>Weight</b>		0.15 kg
<b>Box</b>	Plastic, polycarbonate, grey	
<b>CE</b>	Pursuant to EMC Guide and Low Current Regulation	

**Ordering Information**

Product Name	Product Code	Ordering Code	Package Information
DA100 EAE Knx Dali Gateway V2	SMP DA100 EAE S-KNX	48059	1 unit

# DA110

## EAE KNX-DALI GATEWAY (Individual DALI Ballast Control)



### General Specifications

- DA110 KNX-DALI interface operates as a DALI-IEC 62386 standard compliant gateway between KNX line and DALI. DALI line power supply is available as integrated to the device.
- Maximum of 64 DALI devices can be connected to DALI output (electronic ballast, LED drive, etc).
- The operations such as addressing, grouping, etc. of DALI devices are performed by means of Windows based DALI commissioning software (EAE DALI Commissioning Tool).
- DA110 provides 64 individual ballast control.
- The error status of DALI devices can be received by means of different KNX communication objects on device and group basis.

### Dimensions (mm)

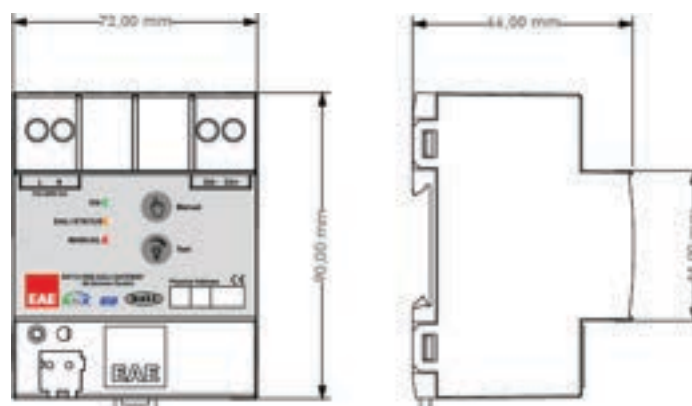

**Technical Information**

<b>Protection Type</b>	IP 20	EN 60529
<b>Safety Class</b>	II	EN 61140
<b>KNX Power Supply</b>	Voltage range Current consumption	21 - 30V DC, SELV < 10mA
<b>External Power Supply</b>	Voltage range Power Consumption Current consumption	85 - 300V AC @ 50-60Hz ≤ 8W 100mA @ 85V AC
<b>DALI Power Supply</b>	Voltage range Current consumption	16V DC ~ ≤ 200mA
<b>Connections</b>	Screw terminal  Maximum Torque KNX Terminal	0,05 - 2,5mm <sup>2</sup> single core cable 0,03 - 1,5mm <sup>2</sup> multi core cable 0.5Nm Red-Black KNX Line Connection
<b>Output</b>	Quantity of DALI devices Cable lengths	Maximum 64 1.5 mm <sup>2</sup> ≤ 300 m 0.75 mm <sup>2</sup> ≤ 150 m 0.5 mm <sup>2</sup> ≤ 100 m
<b>Configuration</b>	35 mm mounting rail	EN 60715
<b>Operating Elements</b>	Programming LED and button Green LED <sup>(7)</sup> Yellow LED <sup>(8)</sup>  Red LED <sup>(9)</sup> Manual Button <sup>(10)</sup> Test Button <sup>(11)</sup>	Used for physical address Problem-free KNX line First start-up (fast flashing) Device failure on DALI Line (slow flashing) Power supply fault (continuously on) Manual control active Entire DALI line on-off, dimming (when manual control is active)
<b>Temperature Range</b>	Operation Storage	-5°C +45°C -25°C +55°C
<b>Dimensions</b>	H x W x D Width W (mm) Width W (unit)	90 mm x W x 66 mm 72 mm 4x18 mm modules
<b>Weight</b>		0.15 kg
<b>Box</b>	Plastic, polycarbonate, grey	
<b>CE</b>	Pursuant to EMC Guide and Low Current Regulation	

**Ordering Information**

Product Name	Product Code	Ordering Code	Package Information
DA110 EAE Knx Dali Gateway	SMP DA110 EAE S-KNX	48107	1 unit

# UD106

## EAE KNX UNIVERSAL DIM MODULE



### General Specifications

- Incandescent lamp, halogen lamp, dimmable LED and fluorescent lamps can be dimmed up to 1800/VA in 6 parallel channels.
- Flexibility to connect loads even below 9W (LED bulbs) without any lower limit
- 6 independent channels that can be parameterized via ETS5 or higher.
- Manual operation feature for each channel using membrane switches.
- Each channel can actualize any of these functions separately.
  - Following function list provided;
    - Staircase lighting
    - Forced Operation
    - Channel Grouping (merging outputs for higher power loads)
    - Scene Function
    - Electrical Measurements (Voltage)
    - Error Detection
- Configurable behaviour after voltage return, voltage failure or ETS download.

### Dimensions (mm):

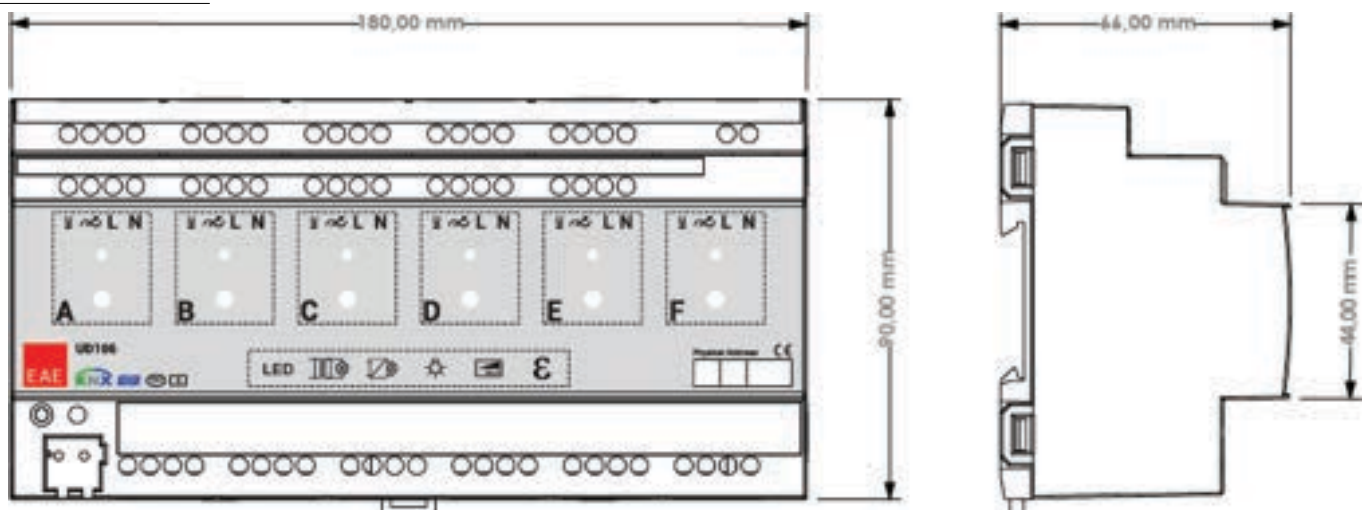

**Technical Information**

<b>Protection Type</b>	IP 20	EN 60529
<b>Safety Class</b>	II	EN 61140
<b>Power Supply</b>	Voltage range	21 - 30V DC, SELV
	Current consumption	< 10mA
<b>Connections</b>	Screw terminals	0,05 - 3,31 mm <sup>2</sup> solid and stranded wire 0,05 - 3,31 mm <sup>2</sup> stranded wire with ferrule
	Max tightening torque	0.78 Nm
	KNX Terminal	Bus connect terminal
<b>Dim Output</b>	Quantity	6 Outputs (can be used in parallel)
	Voltage Range	0...300VAC; 50/60Hz
	Switching Power	6x320VA (1x1920VA)
<b>Type of Load</b>	Incandescent lamps	320 W/VA
	Halogen lamps	320 W/VA
	Inductive transformers	320 W/VA
	Phase dimmable electronic drivers	250 W/VA
	Dimmable LED lamps	250 W/VA
<b>Installation</b>	35mm mounting rail	EN 60715
<b>Operating Elements</b>	LED (red) and button	For physical address
<b>Temperature range</b>	Operation	-5°C +45°C
	Storage	-25°C +55°C
<b>Dimensions</b>	H x W x D	90 mm x W x 66 mm
	Width W (mm)	180 mm
	Width W (unit)	10x18 mm modules
<b>Weight</b>	0,3 kg	
<b>Box</b>	Plastic, polycarbonate, grey	
<b>CE</b>	In accordance with the EMC, LVD and RoHS directives	

# SD110

## EAE KNX 1-10V DIM ACTUATOR

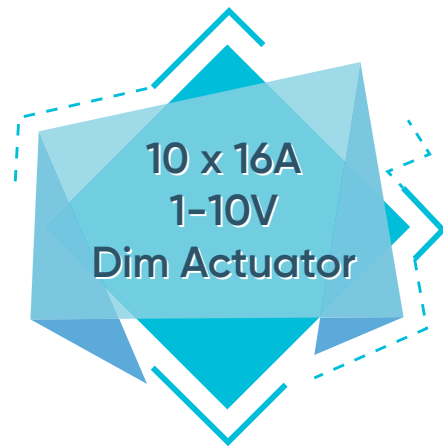

### General Specifications

- 10 independent channels that can be parameterized via ETS5 or higher.
- Manual operation feature for each channel using membrane switches.
- Each channel can actualize any of these functions separately.
  - Following function list provided;
    - Staircase
    - Scene
    - Operating Hour
    - Forced Operation
    - Brightness
    - Relay
    - Current Detection
- Configurable behaviour after voltage return, voltage failure or ETS download.
- Integrated relay on each channel for complete switch off
- Does not require an additional power supply.

### Dimensions (mm):

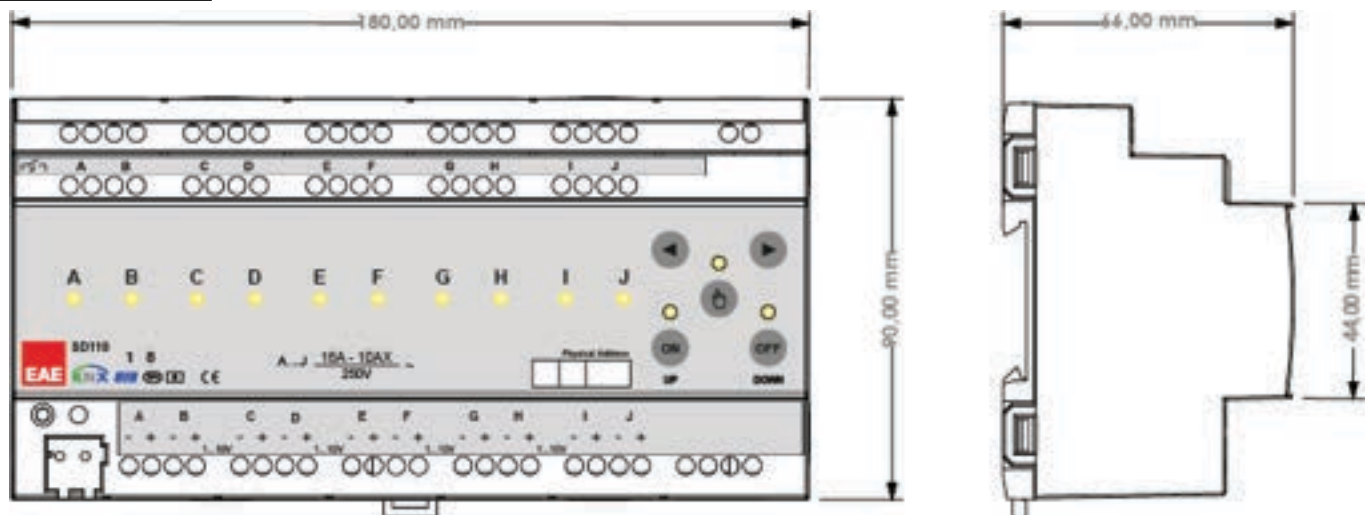

**Technical Information**

<b>Protection Type</b>	IP 20	EN 60529
<b>Safety Class</b>	II	EN 61140
<b>Power Supply</b>	Voltage range	21 - 30V DC, SELV
	Current consumption	< 10mA
<b>Connections</b>	Screw terminals	0,05 - 3,31 mm <sup>2</sup> solid and stranded wire 0,05 - 3,31 mm <sup>2</sup> stranded wire with ferrule
	Max tightening torque	0.5 Nm
	KNX Terminal	Bus connect terminal
<b>Dim Output</b>	Quantity	Max 10 Outputs
	Signal	1-10V DC for dimming control
	Current Limit	30 mA per channel
<b>Relay Output</b>	Quantity	Max 10 Outputs
	Switching ratings	16A 250VAC / 6x10 <sup>3</sup> OPS (Resistive) 3500W 277VAC / 1.2x10 <sup>4</sup> OPS (Incandescent lamp)
	Max. Inrush current	492A/1.5ms - 165A/20ms
	Maximum switching power	4000VA
	Mechanical life	2 x 10 <sup>6</sup>
<b>Type of contact</b>	Potential-free, bistable	
<b>Installation</b>	35mm mounting rail	EN 60715
<b>Operating Elements</b>	LED (red) and button	For physical address
<b>Temperature range</b>	Operation	-5°C +45°C
	Storage	-25°C +55°C
<b>Dimensions</b>	H x W x D	90 mm x W x 66 mm
	Width W (mm)	180 mm
	Width W (unit)	10x18 mm modules
<b>Weight</b>	0,5 kg	
<b>Box</b>	Plastic, polycarbonate, grey	
<b>CE</b>	In accordance with the EMC, LVD and RoHS directives	

**Ordering Information**

Product Name	Product Code	Ordering Code	Package Information
EAE 1-10V Dim Actuator	SMP SD110 EAE S-KNX	48032	1unit

# FCA100

## EAE KNX-FANCOIL ACTUATOR

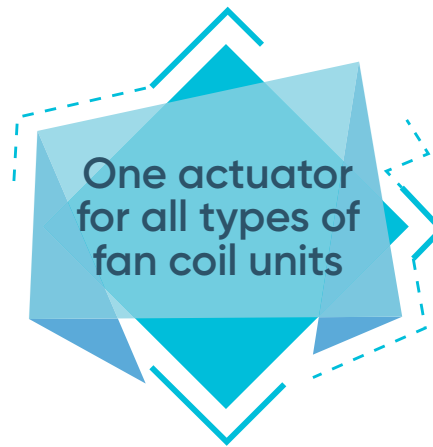

### General Specifications

- Fan Coil Actuator FCA100 is designed as all in one product for different way of Fan coil and Valve control together.
- Fan Coil Actuator FCA100 covers HVAC systems of the electrical installation of room applications and offers following functions in one product.
  - Controlling fan coils (2 & 3-point valve) • Additional Heat or Cooling • Switching auxiliary load
  - Dry contact inputs • Temperature inputs
- FCA100 has 11 outputs, 6 inputs inside. These outputs and inputs are using for:
  - Auxiliary Output x1 (Relay 16A)
  - Fan Speed Output x1 (0-10 V Signal)
  - Valve Control Output x2 (0-10 V Signal)
  - NTC Sensor Input x2
  - Fan Speed Output x3 (Relay 16A)
  - Valve Control Output x4 (Triac 0.5A)
  - Dry Contact Input x4
- Suitable for switching resistive, capacitive and inductive loads as well as fluorescent lamp loads according to EN 60669.
  - Any kind of load (up to 16A per channel)
- Device has 4 independent input channels. Input channel operates as well as universal interface with following functions,
  - Switch / push button sensor • Dew-point sensor • Window sensor
- Manual control is possible for each channel through the built-in button panel.
- Device has 2 temperature input channels separately. Temperature Inputs can be used with following functions
  - Single • Weighted (Multi temp sensor)
- 220V auxiliary power is not required.

### Dimensions (mm)

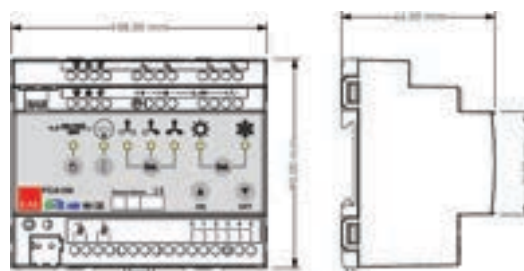



**Technical Information**

<b>Protection Type</b>	IP 20	EN 60529
<b>Safety Class</b>	II	EN 61140
<b>Power supply</b>	Voltage	21V... 30V DC, SELV
	Current consumption	< 10 mA
<b>External supply</b>	-	-
<b>Connections</b>	Screw terminals	0,5...3,31 mm solid and stranded wire 0,5...3,31 mm stranded wire with ferrule
	Max tightening torque	0.5 Nm
	KNX	Bus connect terminal
<b>Output</b>	Quantity	11 output
	Non-floating	Yes, 4 for Heating/Cooling Valve
<i>Triac</i>	Rated Voltage	250 V AC; 50/60 Hz
	Rated Current	0.5 A
	Short-Circuit Protection	Yes
	Switching voltage	250V AC; 50/60 Hz (1 Aux + 3 Fan Speed)
<i>Relay</i>	Switching capacity 250V AC	16A / AC 1
	Switching current 250 V AC, capacitive loads	16A (200µF)
	Maximum switching power	4000 VA
	Mechanical life	> 1 x 10 <sup>6</sup>
<i>0-10V</i>	Current Limit	1.40mA (1 Fan Speed + 2 Valve)
	Signal	0...10V DC
	Source/Sink	Source
<b>Input</b>	Quantity	6 Inputs
	Scanning Voltage (for binary input)	5 V pulsed (4 Input)
<i>Generic Input</i>	Current (for binary input)	1 mA
	Cable length	<300 m
<i>Temp. Input</i>	Sensor Type	NTC (2 Input)
<b>Installation</b>	35 mm mounting rail	EN 60715
<b>Operating elements</b>	LED (red) and prg. button	For physical address
	Manual Button	Switching to manual mode
	Sel. Buttons	Fan speed and HVAC mode change
	ON / OFF Buttons	Switching Valve ON / OFF
	Switch Button	Auxiliary Output Control
<b>Temperature range</b>	Operation	-5° C + 45° C
	Storage	-25° C + 55° C
<b>Dimensions</b>	H x W x D	90 mm x W x 66 mm
	Width W (mm)	108 mm
	Width W (unit)	6x18 mm modules
<b>Weight</b>	0.395 kg	
<b>Box</b>	Plastic, polycarbonate, grey	
<b>CE</b>	In accordance with the EMC guideline and low voltage	

**Ordering Information**

Product Name	Product Code	Ordering Code	Package Information
EAE KNX Fancoil Actuator	SMP FCA100 EAE F-KNX	48132	1 unit

# PS320 / PS640

EAE KNX – POWER SUPPLY



## General Specifications

- EAE KNX Power Supply is available in 320 mA and 640 mA versions.
- Input voltage range 150–275V AC, 50/60Hz
- Both models have two voltage outputs.
  - Output 1: KNX bus power with an integrated choke. (30VDC, SELV)
  - Output 2: Additional voltage output. (30VDC, SELV)
- Power supply outputs are short-circuit and overload protected.
- Power, Overload and Reset statuses are indicated with three different LED indicators
- Device can be restarted by pressing reset button on the device.

## Dimensions (mm)

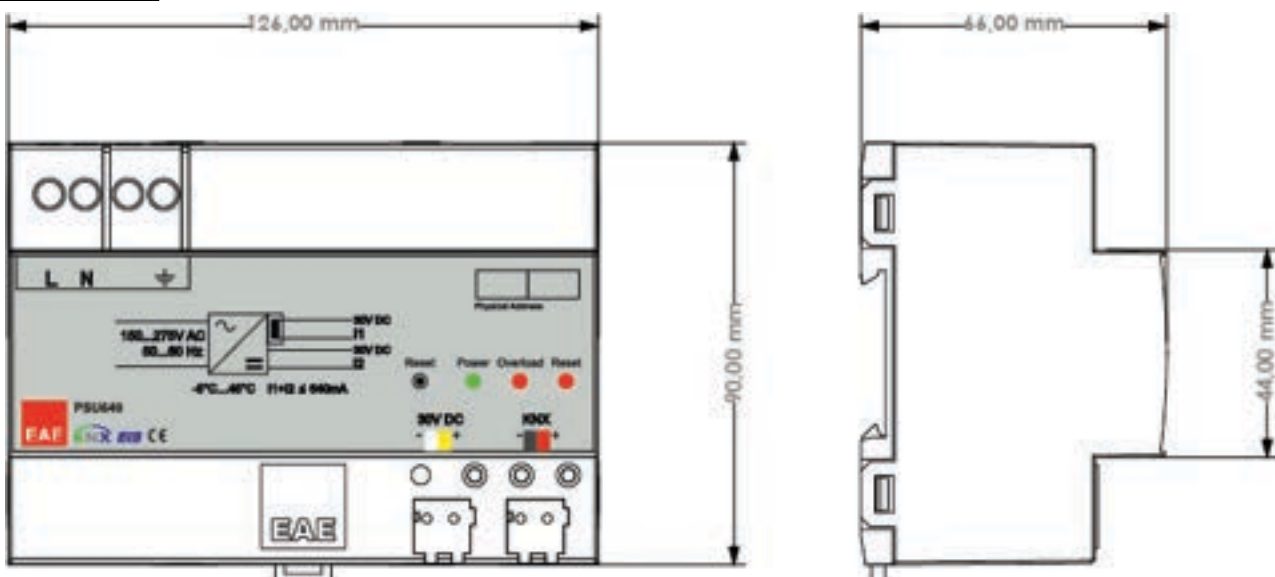

**Technical Information**

<b>Protection Type</b>	IP 20	EN 60529
<b>Safety Class</b>	II	EN 61140
<b>Insulation category</b>	Over voltage category Pollution degree	III EN 60664-1 2 EN 60664-1
<b>Power Supply</b>	Input voltage Power consumption PS320 Power consumption PS640 Power loss PS320 Power loss PS640	150-275V AC, 50-60Hz 11,5 W 22 W 2 W 3,6 W
<b>Output</b>	Output 1  Output 2 Short-circuit current PS320 Short-circuit current PS640	KNX bus 30 VDC +1/-2 V, SELV (integrated choke) 30 VDC +1/-2 V, SELV (without choke) 1 A 1,5 A
<b>Connections</b>	Screw terminal  Maximum torque KNX	0,2 – 5,3 mm solid and stranded wire 0,2 – 5,3 mm stranded wire with ferrule 0.78 Nm Red-Black KNX Bus
<b>Installation</b>	35mm mounting rail	EN 60715
<b>Operational elements</b>	Power (green) Overload (red) Reset button and LED (red)	ON: Input voltage and KNX voltage is OK. ON: Overload or short-circuit. ON: Reset in progress. Press and hold reset button until the reset LED lights up. No power on KNX bus for 20 s. After reset, reset LED will turn off.
<b>Temperature</b>	Operation Storage	-5° C + 45° C -25° C + 55° C
<b>Dimensions</b>	H x W x D Width W (mm) Width W (unit)	90 mm x W x 66 mm 126 mm 7 x18 mm modules
<b>Weight</b>	PS320 PS640	0.28 kg 0,29 kg
<b>Box</b>	Plastic, polycarbonate, grey	
<b>CE</b>	In accordance with the EMC guideline and low voltage	

**Ordering Information**

Product Name	Product Code	Ordering Code	Package Information
EAE KNX Power Supply 640mA	SMP PS640A EAE S-KNX	48023-640	1 unit
EAE KNX Power Supply 320mA	SMP PS320A EAE S-KNX	48023-320	1 unit

# KMG103

## EAE KNX MODBUS GATEWAY

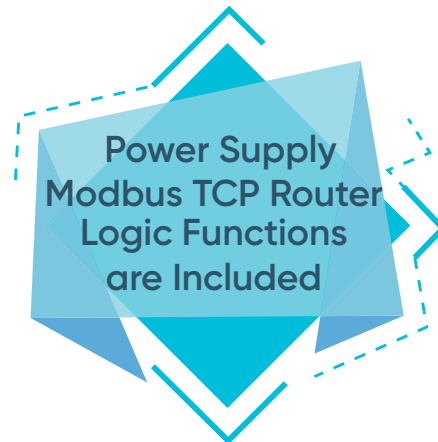

### General Specifications

- EAE KMG103 can be used to control and monitor KNX installations via SCADA visualization software.
- IP address of device can be given by DHCP server or by manual configuration.
- EAE KMG103 includes patent-pending logic controller that enables room energy saver system without using card holder.
- Device has 3 physical inputs for door, window and presence sensing.
- EAE KMG103 has built-in 320mA or 640 mA KNX bus power supply for KNX devices. (110V, 220V AC are available)
- KNX Power supply output is short-circuit and overload protected.
- Power, overload and reset statuses are indicated with three different LED indicators.
- Power supply can be restarted by pressing reset button on the device.

### Dimensions (mm)

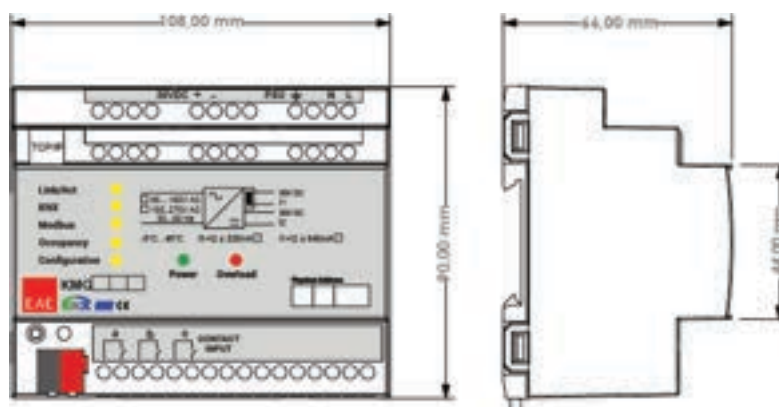

Technical Information

Type of Protection	IP 20	EN 60529
Safety Class	II	EN 61140
Insulation Category	Over voltage category	III EN 60664 - 1
	Pollution Degree	2 EN 60664 - 1
Power Supply	Input Voltage	150-275V AC, 50-60Hz
	Power consumption	7W
Output	KNX Bus	30 VDC +1 / -2V, SELV (Integrated choke) 320mA - 640mA
Connection	IP Line	RJ45 socket for 10/100BaseT, IEEE 802.3 networks
	KNX Line	Bus Connection Terminal
Display Elements	ETH Link	Status
	ETH Act	Fault
Operating Elements	Function button	
Installation	35mm DIN rail mount	EN 60715 TH 35-75
Temperature Range	Operation	- 5°C +45°C non-condensing
	Storage	-20°C + 60°C
Dimensions	H x W x D	90 mm x W x 66 mm
	Width W (mm)	108 mm
	Width W (units)	6x18 mm modules
Weight	66g	
Box	Polycarbonate	
CE	In accordance with EMC and low voltage guidelines Device complies with, EN 50090-2-2, IEC 60664-1	

Ordering Information

Product Name	Product Code	Ordering Code	Package Information
EAE KNX Modbus Gateway	SMP KMG103 EAE S-KNX (320mA)	48198	1 unit

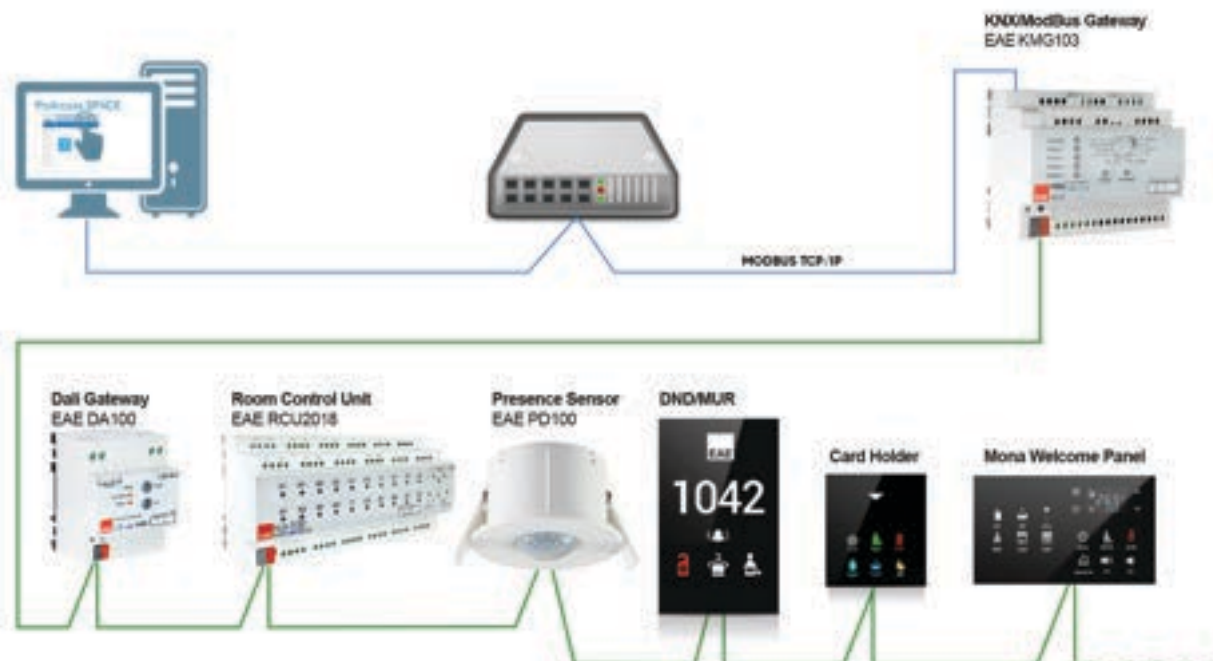

# KMG103

## EAE KNX MODBUS GATEWAY

### KMG Function Diagram

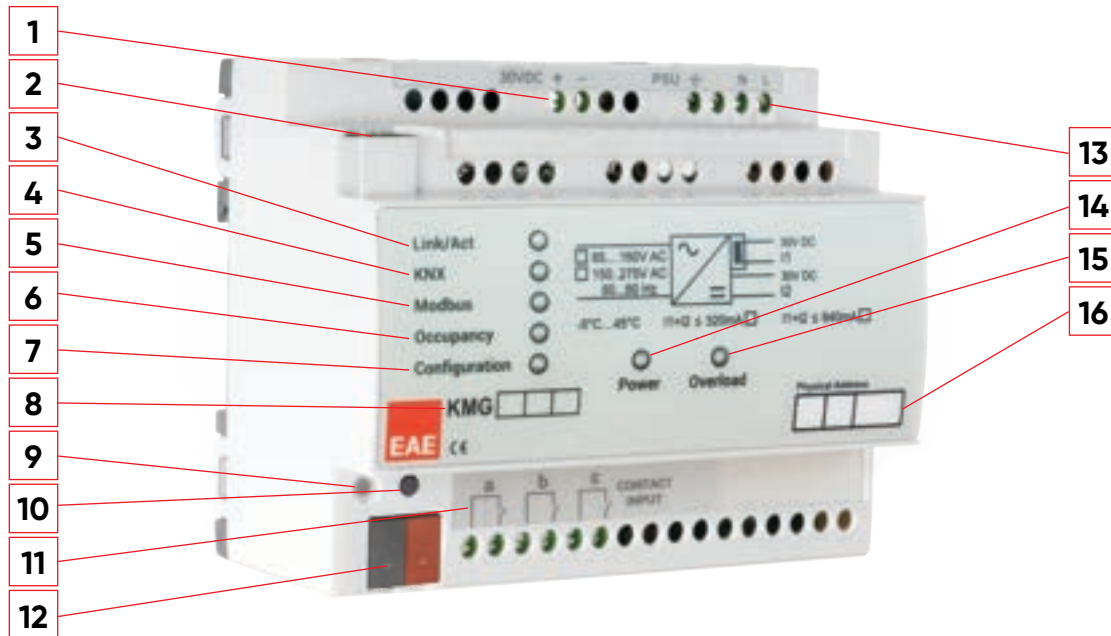

No	Function
1	KNX Auxiliary Output - 30V
2	CAT6 Modbus TCP/IP Connection
3	Ethernet Connection / Transmission LED
4	KNX Connection / Transmission LED
5	Modbus Connection / Transmission LED
6	Occupancy State LED
7	PC Configurator Software Connection LED
8	Model Name Label

No	Function
9	Reset LED
10	Reset / Factory Reset Button
11	Dry Contact Inputs (Presence A, Door B, Window C)
12	KNX Connection Terminal
13	Power Supply Input
14	Power LED
15	Overload LED
16	Physical Address Label

- KMG is also a gateway between KNX line and Modbus TCP line. Device is reaching Modbus TCP line directly.
- Device has 3 dry contact inputs for ; Doors, Windows and Presence.
- Power, overload and reset statuses are indicated with three different LED indicators. KNX Power supply output is short-circuit and overload protected.
- Power supply can be restarted by pressing reset button on the device.

## KMG Logic Function and Scenes

More energy saving becomes easier with the KNX / Modbus Gateway device. 8 different scenarios can be defined for KMG.

### 1- Pre-Welcome Scene

Room must be unoccupied. Then the door should be opened and closed. Later then, detector will be activated to check any movement in a certain time. If any movement detected in Presence Wait Time, this scene will be executed.

### 2. Welcome Scene

During the welcome scenario, as long as the guests are in the room, the use of lighting, HVAC, shading, socket is allowed in the room.

### 3. Leave Primary Scene

The room should be occupied and the door should be opened and closed. Then, detector will be activated to check any movement for a certain time. If no movement is detected at the end of the Presence Wait Time, then additional Leave Scene Primary Delay Time will be set after. When this time is ended, this scene will be executed.

### 4. Leave Secondary Scene

When the Leave Scene Primary scene is executed, then Leave Scene Secondary Delay time will be set. After end of the delay time this scene will be executed.

### 5. Window Open Scene

This scene will be executed if Window dry contact input or assigned KNX Input (for Window) is triggered. This function can be selected at KMG Input/IP Config section of the configurator.

### 6. Check-in Scene

This scene will be executed if CHECK IN/OUT OBJECT Active value is received from KNX. This function should be selected at KMG Input/IP Config section of the configurator.

### 7. Checkout Scene

This scene will be executed if CHECK IN/OUT OBJECT De-active value is received from KNX. This function should be selected at KMG Input/IP Config section of the configurator.

### 8. Service(Staff) Entry scene

If the room state is set to the CHECK-OUT via Check-in/out KNX object and opened the door, this scene will be executed.

## GRMS Solution without using Card Holder

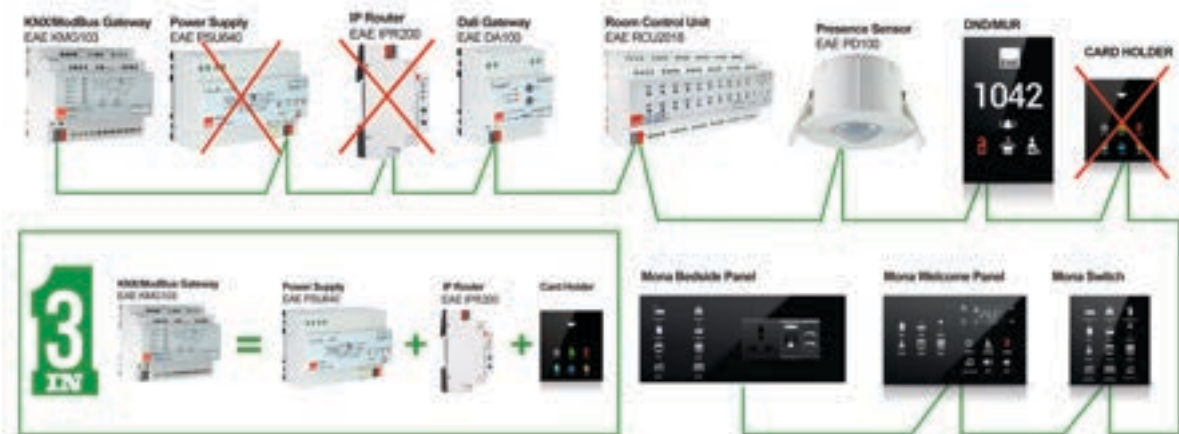

## GRMS Solution with using Card Holder

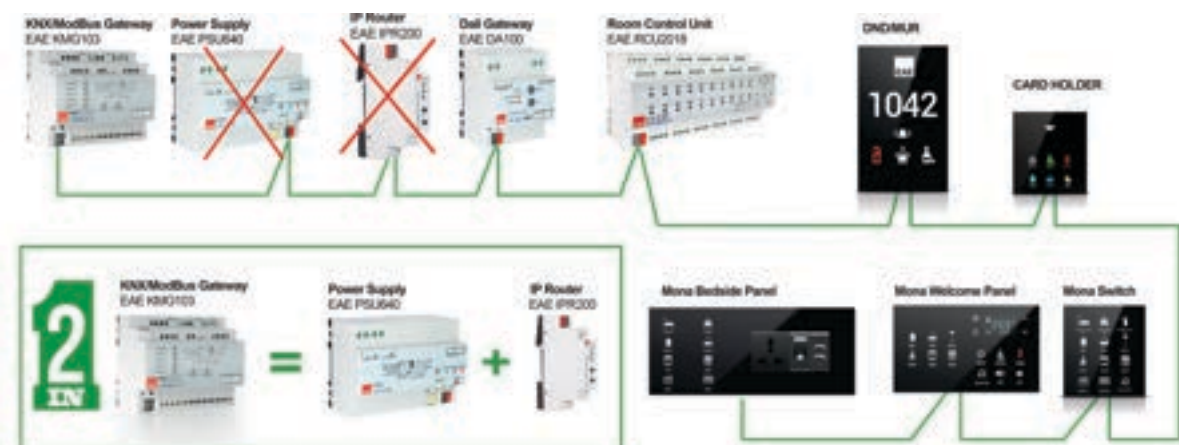

# UI108

## EAE KNX-UNIVERSAL INTERFACE

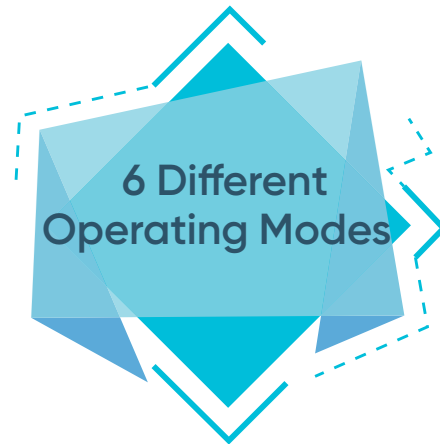

### General Specifications

- 8 functional input channels that could be adjusted by means of ETS5 or higher.
- Easy connection with colored connection cables.
- Use by means of conventional switches/buttons upon installation in flush mounted switch boxes.
- Means for including the devices reporting dry contact information, in KNX line.
- The channels are identical with each being in possession of the following functions:
  - Switching
  - Dimming
  - Curtain control
  - Value and priority information relay
  - Scene control
  - Pulse counter

### Dimensions (mm)

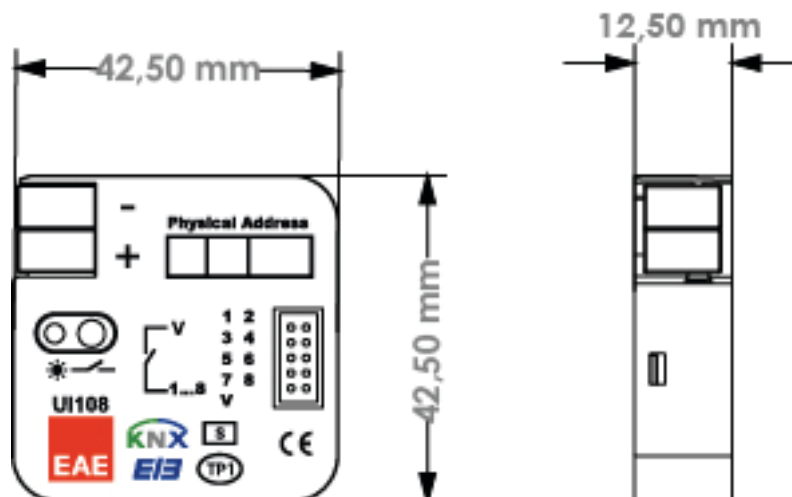



**Technical Information**

<b>Power Supply</b>	Voltage range Current consumption	21 - 30V DC, KNX Line < 10mA
<b>Inputs</b>	Quantity of connection points	8inputs
<b>Input</b>	Permitted cable length	≤ 10 m
	Detected Voltage	3.3 V DC
	Input current	0.5 mA
	Safety	Short circuit protection, over voltage protection, reverse voltage protection
<b>Operating Elements</b>	LED (Red) and button	Used for programming the device
<b>Connections</b>	Inlets KNX	2 x 5 Connector Bus connect terminal
<b>Temperature Range</b>	Operation Storage	-5°C +45°C -25°C +55°C
<b>Dimensions</b>	42.5 mm x 42.5 mm x 12 mm	
<b>Weight</b>	0.06 kg	
<b>Box</b>	Plastic, polycarbonate, grey	
<b>CE</b>	Pursuant to EMC Guide and Low Current Regulation	

**Ordering Information**

Product Name	Product Code	Ordering Code	Package Information
EAE Universal Interface Module – 8 ch.	SMP UI108 EAE S-KNX	48003	1 unit

# ACGME100

## EAE KNX-MITSUBISHI ELECTRIC AC GATEWAY



### General Specifications

- Customizable AC functions for optimum control
- Operating Hours & Alarm
- Remote Lock Functionality
- Bus Return AC behaviors
- Scene Function
- Energy Saver functions (Window/Door Sensor and Auto OFF Timer)
- Logic Function

### Dimensions (mm)

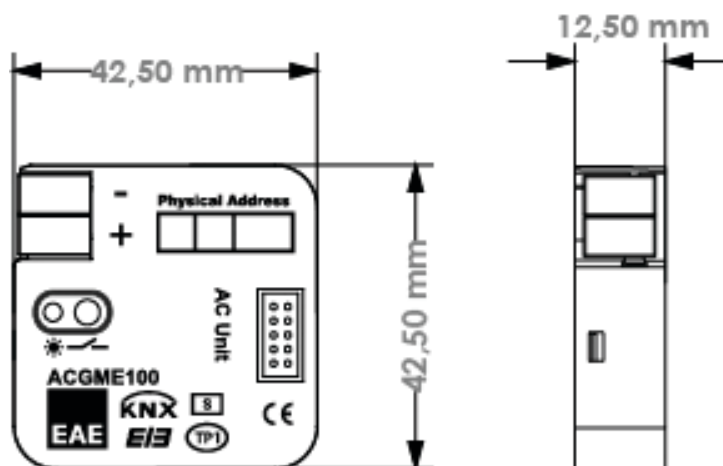

Technical Information

Safety Rating	IP20	EN 60529
Safety Class	II	EN 61140
Power supply	Voltage	22V... 30V DC, via the KNX bus
	Current consumption	≤10mA
AC Com Port	Cable length	≤3 m
Operating elements	LED (red) and button	For physical address
Temperature range	Operation	-5° C + 45° C
	Storage	-25° C + 55° C
Dimensions	42,5 mm x 42,5 mm x 12,8 mm	
Weight	0.06 kg	
Box	Plastic, polycarbonate, grey	
CE	In accordance with the EMC guideline and low voltage directives.	

Ordering Information

Product Name	Product Code	Ordering Code	Package Information
EAE Mitsubishi Electric AC KNX Gateway	ACGME100	48262	1 unit

Easy Installation And Integration

Mitsubishi Electric AC has quite easy installation. It can be installed in a suitable location far-off Mitsubishi Electric air conditioner or inside the Mitsubishi Electric AC unit. By working compatible and interactive with other KNX applications, it enables energy efficiency to remain in the highest level.

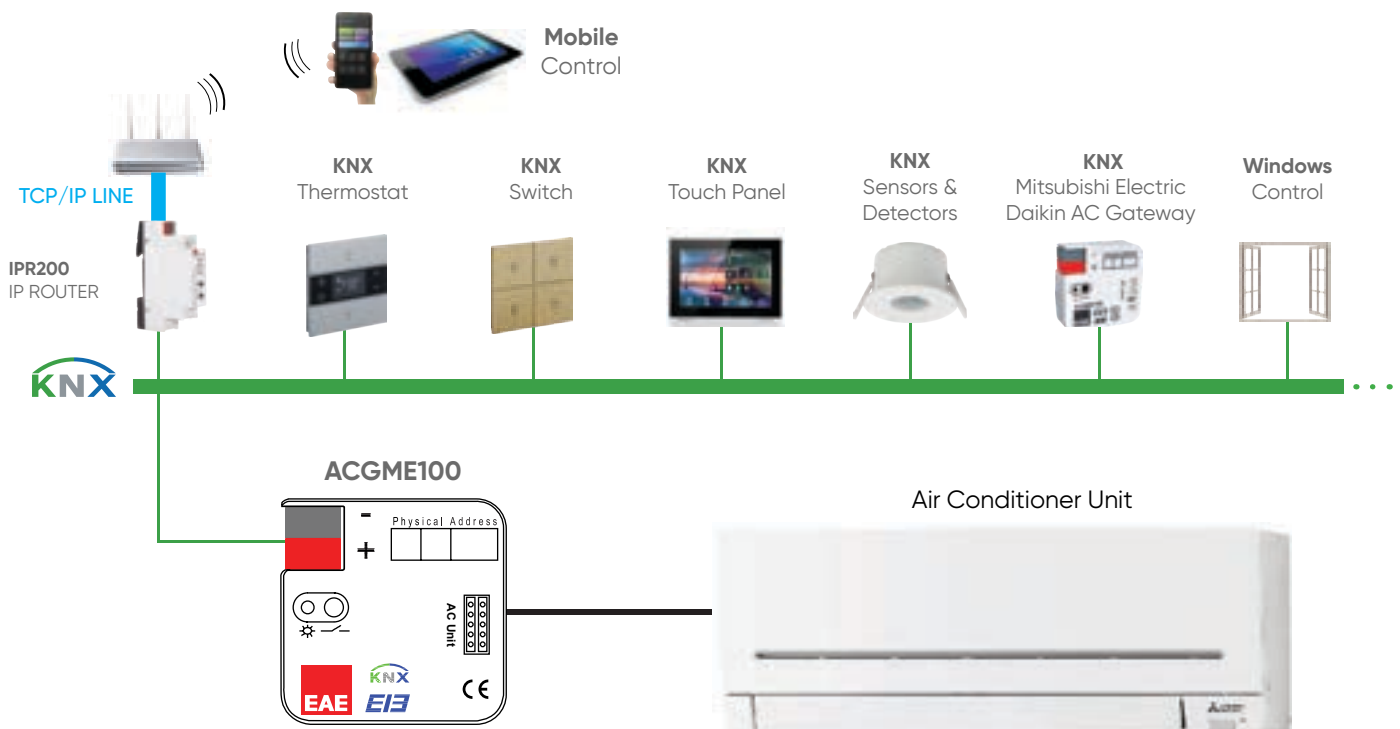

# ACGDAI100

## EAE KNX-DAIKIN AC GATEWAY



### General Specifications

- Customizable AC functions for optimum control
- Operating Hours & Alarm
- Remote Lock Functionality
- Bus Return AC behaviors
- Scene Function
- Energy Saver functions (Window/Door Sensor and Auto OFF Timer)
- Logic Function

### Dimensions (mm)

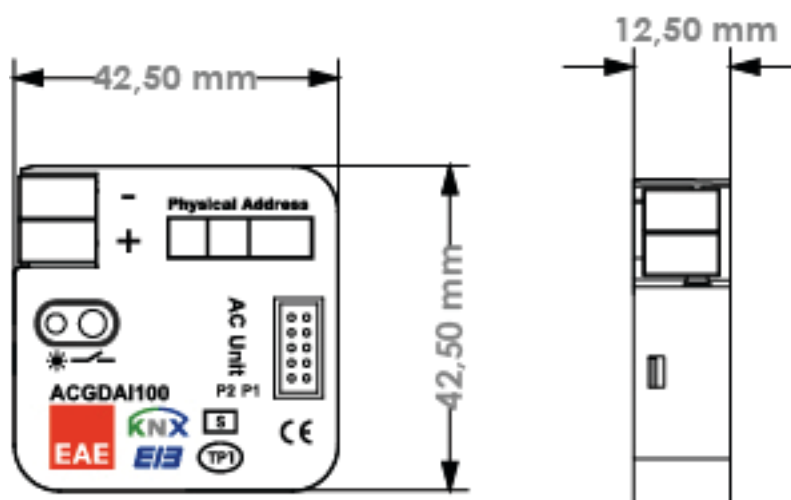

Technical Information

Safety Rating	IP20	EN 60529
Safety Class	II	EN 61140
Power supply	Voltage	22V... 30V DC, via the KNX bus
	Current consumption	≤10mA
AC Com Port	Cable length	≤3 m
Operating elements	LED (red) and button	For physical address
Temperature range	Operation	-5° C + 45° C
	Storage	-25° C + 55° C
Dimensions	42,5 mm x 42,5 mm x 12,8 mm	
Weight	0.06 kg	
Box	Plastic, polycarbonate, grey	
CE	In accordance with the EMC guideline and low voltage directives.	

Ordering Information

Product Name	Product Code	Ordering Code	Package Information
EAE Daikin AC KNX Gateway	ACGDAI100	48267	1 unit

Easy Installation And Integration

Daikin AC KNX Gateway has quite easy installation.

It can be installed in a suitable location far-off Daikin AC air conditioner or inside the Daikin AC unit. By working compatible and interactive with other KNX applications, it enables energy efficiency to remain in the highest level.

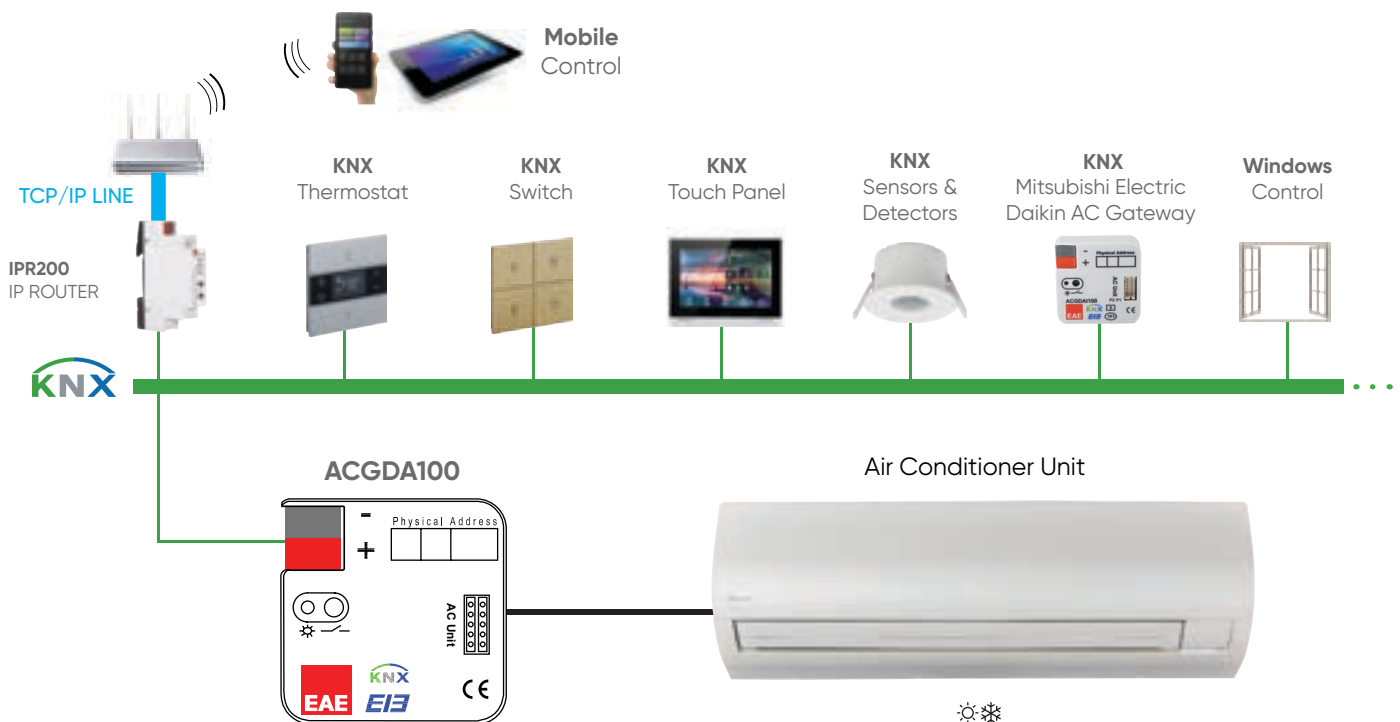

# MIO1616

## EAE KNX – MULTI INPUT/OUTPUT

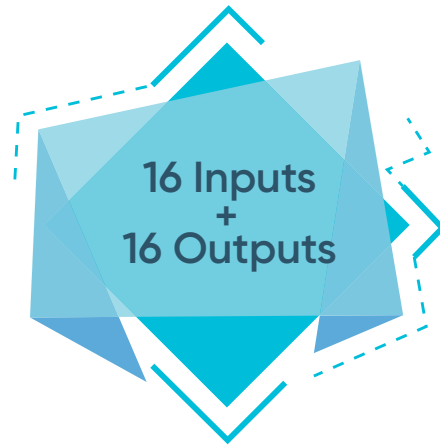

### General Specifications

- The KNX Multi Input/output MIO1616 provides multiple connections for push buttons and signal lamps for building functions in one device.
- All channels can be parameterized independently with ETS5 or higher version.
- MIO1616 has 16 input channels and 16 output channels
- 16 input channels provide following function list,
  - Switch / push button input
  - Dimmer control
  - Control of shutter/blinds
  - Value
  - Scene control
  - Counter for count pulse
- 16 output channels provide following function list,
  - LED control
- Does not require an external power supply

### Dimensions (mm)

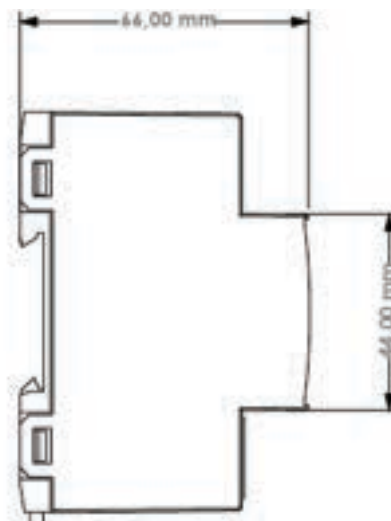
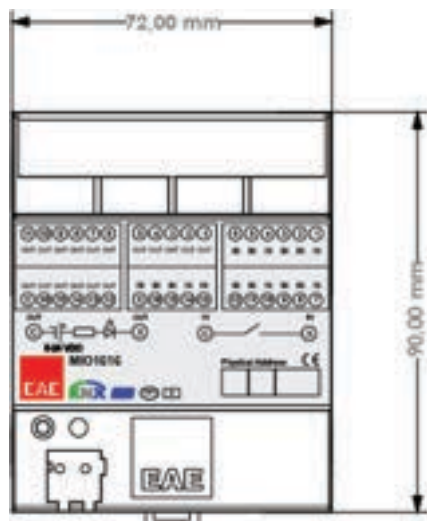

### Technical Specifications

Type of Protection	IP20	EN 60529
Safety Class	II	EN 61140
Power Supply	Voltage	21V... 30V DC, KNX Line
	Current consumption	<10 mA
Inputs	Quantity	16 inputs
	Maximum cable length	<10 m
Input	Scanning voltage	5V DC
	Input current	0.5 mA
Outputs	Quantity	16 outputs
	Maximum cable length	<10 m
Output	Output current	400 mA
	Load type	Resistive
Operating Elements	LED (red) and button	For physical address
Connections	Input /Output	
	KNX	Bus connect terminal
Temperature Range	Operation	-5° C + 45° C
	Storage	-25° C + 55° C
Dimensions	H x W x D	90 mm x W x 66 mm
	Width W in (mm)	72 mm
	Width W (unit)	4x18 mm modules
Weight	0.15 kg	
Box	Plastic, polycarbonate, grey	
CE	In accordance with the EMC guideline and low voltage	

### Ordering Information

Product Name	Product Code	Ordering Code	Package Information
EAE KNX – Multi Input / Output	SMP MIO1616 EAE S-KNX	48026	1 unit

# IPR200

## EAE KNX-IP ROUTER



### General Specifications

- The device supports 5 simultaneous KNXnet/IP Tunneling connections.
- The IPR200 with compact design has a width of only 1 module (18 mm) and is powered by the KNX bus.
- The device forwards telegrams between different KNX TP lines via LAN (IP) as a fast backbone and is an alternative to KNX line coupler.
- The IPR200 can also be used in the ETS® as a programming interface.
- The IP address can be obtained by a DHCP server or by manual configuration (ETS) respectively.
- The IPR200 has a full-range filter table and a large telegram buffer.
- The buttons and LEDs on the device allow a local diagnosis including the operating status and communication errors.
- **Controls and indicators:** 2 buttons + KNX programming button, 3 LEDs bicolor + KNX programming LED
- **Ethernet:** 10BaseT, 5 KNXnet/IP Tunneling connections
- **KNX:** Medium IP/TP, Filter table 8 kByte (64k group addresses), Long Frame
- **Connectors:** KNX connector, LAN RJ-45 socket

### Dimensions (mm)

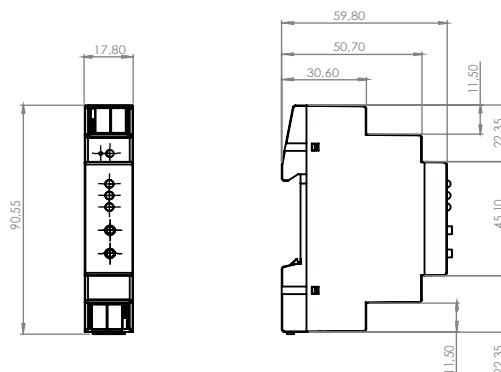



**Technical Information**

<b>Protection Type</b>	IP 20	IEC 60529
<b>Safety Class</b>	III	IEC 61140
<b>Degree of Pollution</b>	2	IEC 60664
<b>Overvoltage Class</b>	III	IEC 60664
<b>Power Supply</b>	Voltage	21...30V DC, SELV
	Current Consumption	< 15 mA
<b>Connections</b>	KNX Line	Bus connection terminal
	IP Line	RJ45 socket
<b>Operating Elements</b>	Function button, programming button, LEDs	
<b>Installation</b>	18 mm DIN rail mount	EN 60715 TH 35-75
<b>Temperature Range</b>	Operation	-5° C + 45° C
	Storage	-25° C + 70° C
<b>Dimensions</b>	H x W x D	90 mm x W x 60 mm
	Width W in (mm)	18 mm
	Width W (unit)	1x18 mm modules
<b>Weight</b>	40 g	
<b>Box</b>	Housing: Plastic (PC)	
<b>CE</b>	In accordance with EMC and low voltage directives.	

**Ordering Information**

Product Name	Product Code	Ordering Code	Package Information
EAE IPR200 KNX-IP Router	SMP IPR200 IP ROUTER	50563	1 unit

# IPR200S

## EAE KNX-IP ROUTER SECURE



### General Specifications

Same features with IPR200  
Additional;

The KNX standard was extended by KNX Security to protect KNX installations from unauthorized access.

- **Controls and indicators:** 2 buttons and 3 LEDs, multicolor, KNX programming button with LED (RD)
- **Ethernet:** 100BaseT (100MBit/s), 8 KNXnet/IP Tunneling connections, Supported internet protocols ARP, ICMP, IGMP, UDP/IP, TCP/IP, DHCP and Auto IP
- **KNX:** Medium IP/TP, KNXnet/IP Routing, KNXnet/IP Tunneling, Long Frame, KNX Security (AES-128), Tunneling V2, Core V2, Up to 8 KNXnet/IP Tunneling connections simultaneously, Extended filter table for main group 0..31
- **Connectors:** KNX connector, LAN RJ-45 socket

### Dimensions (mm)

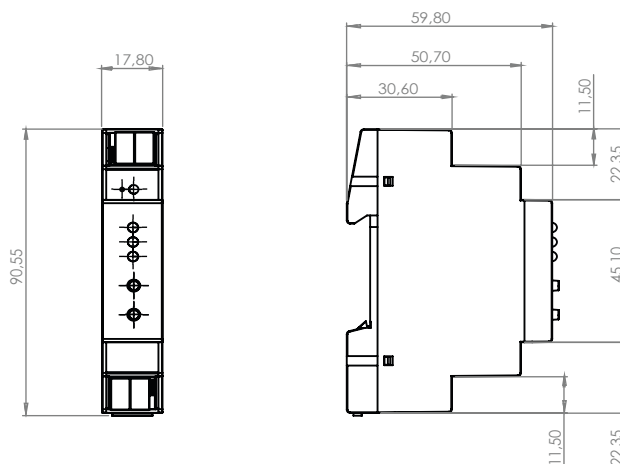

**Technical Information**

<b>Protection Type</b>	IP 20	IEC 60529
<b>Safety Class</b>	III	IEC 61140
<b>Degree of Pollution</b>	2	IEC 60664
<b>Overvoltage Class</b>	III	IEC 60664
<b>Power Supply</b>	Voltage	21...30V DC, SELV
	Current Consumption	< 20 mA
<b>Connections</b>	KNX Line	Bus connection terminal
	IP Line	RJ45 socket
<b>Operating Elements</b>	Function button, programming button, LEDs	
<b>Installation</b>	18mm DIN rail mount	EN 60715 TH 35-75
<b>Temperature Range</b>	Operation	-5° C + 45° C
	Storage	-25° C + 70° C
<b>Dimensions</b>	H x W x D	90 mm x W x 60 mm
	Width W in (mm)	18 mm
	Width W (unit)	1x18 mm modules
<b>Weight</b>	40 g	
<b>Box</b>	Housing: Plastic (PC)	
<b>CE</b>	In accordance with EMC and low voltage directives.	

**Ordering Information**

Product Name	Product Code	Ordering Code	Package Information
EAE IPR200S KNX-IP Router Secure	SMP IPR200S IP ROUTER SECURE	-	1 unit

# IPI200

## EAE KNX-IP INTERFACE



### General Specifications

- The device supports 5 simultaneous KNXnet/IP Tunneling connections.
- The IPI200 with compact design has a width of only 1 module (18 mm) and is powered by the KNX bus.
- The device forwards telegrams between different KNX TP lines via LAN (IP) as a fast backbone and is an alternative to KNX line coupler.
- The IPI200 can also be used in the ETS® as a programming interface.
- The IP address can be obtained by a DHCP server or by manual configuration (ETS) respectively.
- The IPI200 has a full-range filter table and a large telegram buffer.
- The buttons and LEDs on the device allow a local diagnosis including the operating status and communication errors.
- **Controls and indicators:** 2 buttons and 3 LEDs, multicolor, KNX programming button with LED (RD)
- **Ethernet:** 10BaseT, 5 KNXnet/IP Tunneling connections
- **KNX:** Medium IP/TP, Long Frame
- **Connectors:** KNX Bus connector, LAN RJ-45 socket

### Dimensions (mm)

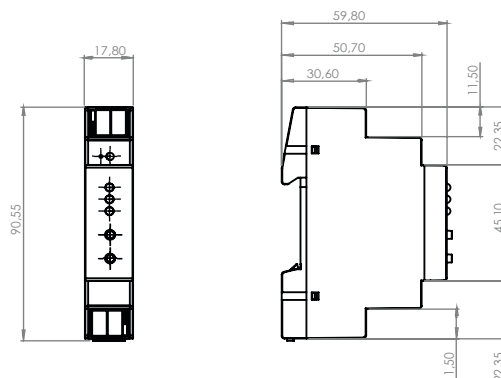

### Technical Information

Protection Type	IP 20	IEC 60529
Safety Class	III	IEC 61140
Degree of Pollution	2	IEC 60664
Overvoltage Class	III	IEC 60664
Power Supply	Voltage	21...30V DC, SELV
	Current Consumption	< 15 mA
Connections	KNX Line	Bus connection terminal
	IP Line	RJ45 socket
Operating Elements	Function button, programming button, LEDs	
Installation	18mm DIN rail mount	EN 60715 TH 35-75
Temperature Range	Operation	-5° C + 45° C
	Storage	-25° C + 70° C
Dimensions	H x W x D	90 mm x W x 60 mm
	Width W in (mm)	18 mm
	Width W (unit)	1x18 mm modules
Weight	40 g	
Box	Housing: Plastic (PC)	
CE	In accordance with EMC and low voltage directives.	

### Ordering Information

Product Name	Product Code	Ordering Code	Package Information
EAE IPI200 KNX-IP Gateway	SMP IPI200 IP INTERFACE	50562	1 unit

# IPI200S

## EAE KNX-IP INTERFACE SECURE



### General Specifications

- The device supports 8 simultaneous KNXnet/IP Tunneling connections.
- The IPI200S with compact design has a width of only 1 module (18 mm) and is powered by the KNX bus.
- The device forwards telegrams between different KNX TP lines via LAN (IP) as a fast backbone and is an alternative to KNX line coupler.
- The IPI200S can also be used in the ETS® as a programming interface.
- The IP address can be obtained by a DHCP server or by manual configuration (ETS) respectively.
- The IPI200S has a full-range filter table and a large telegram buffer.
- The buttons and LEDs on the device allow a local diagnosis including the operating status and communication errors.
- **Controls and indicators:** 2 buttons and 3 LEDs, multicolor, KNX programming button with LED (RED)
- **Ethernet:** 100BaseT(100MBit/s), Supported internet protocols ARP, ICMP, IGMP,UDP/IP, TCP/IP, DHCP and Auto IP.
- **KNX:** Medium TP, Long Frame, KNXnet/ IP tunneling, KNX IP Security (AES-128), Tunneling V2, Core V2, Up to 8 connections at the same time
- **Connectors:** KNX Bus connector, LAN RJ-45 socket

### Dimensions (mm)

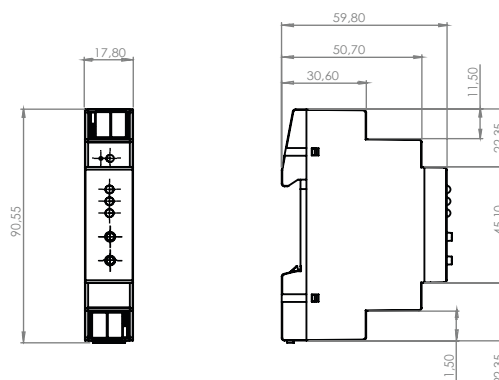

**Technical Information**

<b>Protection Type</b>	IP 20	IEC 60529
<b>Safety Class</b>	III	IEC 61140
<b>Degree of Pollution</b>	2	IEC 60664
<b>Overvoltage Class</b>	III	IEC 60664
<b>Power Supply</b>	Voltage	21...30V DC, SELV
	Current Consumption	< 20 mA
<b>Connections</b>	KNX Line	Bus connection terminal
	IP Line	RJ45 socket
<b>Operating Elements</b>	Function button, programming button, LEDs	
<b>Installation</b>	18mm DIN rail mount	EN 60715 TH 35-75
<b>Temperature Range</b>	Operation	-5° C + 45° C
	Storage	-25° C + 70° C
<b>Dimensions</b>	H x W x D	90 mm x W x 60 mm
	Width W in (mm)	18 mm
	Width W (unit)	1x18 mm modules
<b>Weight</b>	40 g	
<b>Box</b>	Housing: Plastic (PC)	
<b>CE</b>	In accordance with EMC and low voltage directives.	

**Ordering Information**

Product Name	Product Code	Ordering Code	Package Information
EAE IPI200S KNX-IP Gateway	SMP IPI200S IP INTERFACE SECURE	50562	1 unit

# LC200

## EAE KNX-LINE COUPLER

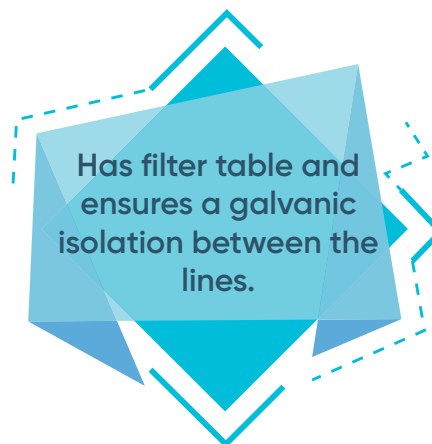

### General Specifications

- The EAE LC200 Line Coupler connects two KNX segments (for example, a KNX line with a KNX area). It has a very compact design.
- The device has a filter table (8K bytes) for main group 0..31 and ensures a galvanic isolation between the lines.
- The coupler supports KNX longframes and is compatible with the ETS® software (ETS5 or higher).
- The buttons on the front panel allow disabling the telegram filter for testing purposes.
- The LEDs indicate the operating status and communication errors on the bus.
- The power is supplied via the KNX bus (main line).on the bus.
- **User Interface:** Two keys for on device settings, three multi color LEDs, KNX programming LED and KNX programming key
- **KNX:** Medium TP/TP, Filter table 8k Byte, Long Frame
- **Connectors:** Connector for KNX-TP main line (red/black), Connector for KNX-TP sub line (red/black)

### Dimensions (mm)

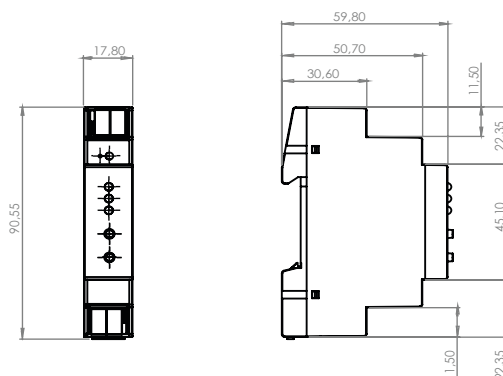



**Technical Information**

<b>Protection Type</b>	IP 20	EN 60529
<b>Safety Class</b>	III	IEC 61140
<b>Power Supply</b>	Voltage	21...30V DC, SELV
	Current Consumption (main)	< 5 mA
	Current Consumption (sub)	< 3 mA
<b>Connections</b>	KNX Line (main)	Bus connection terminal
	KNX Line (sub)	Bus connection terminal
<b>Operating Elements</b>	Function button, programming button, LEDs	
<b>Installation</b>	18mm DIN rail mount	EN 60715 TH 35-75
<b>Temperature Range</b>	Operation	-5° C + 45° C
	Storage	-25° C + 70° C
<b>Dimensions</b>	H x W x D	90 mm x W x 60 mm
	Width W in (mm)	18 mm
	Width W (unit)	1x18 <b>mm modules</b>
<b>Weight</b>	40 g	
<b>Box</b>	Housing: Plastic	
<b>CE</b>	In accordance with EMC and low voltage directives.	

**Ordering Information**

Product Name	Product Code	Ordering Code	Package Information
EAE KNX - Line Coupler	SMP LC200 EAE S-KNX	50562	1 unit

# LC200S

## EAE KNX-LINE COUPLER SECURE

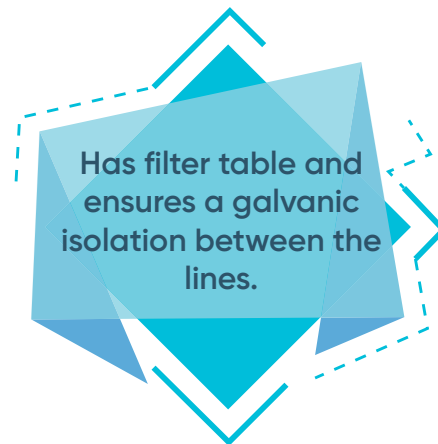

### General Specifications

- The EAE LC200S Line Coupler connects two KNX segments (for example, a KNX line with a KNX area). It has a very compact design.
- The device has a filter table (8K bytes) for main group 0..31 and ensures a galvanic isolation between the lines.
- Line coupler supports KNX longframes and is compatible with the ETS® software (ETS5 or higher).
- The buttons on the front panel allow disabling the telegram filter for testing purposes.
- The LEDs indicate the operating status and communication errors on the bus.
- The power is supplied via the KNX bus (main line).on the bus.
- **User Interface:** 2 buttons and 3 LEDs (multicolor), KNX programming button with LED (red)
- **KNX:** Medium TP/TP, KNX Security (AES-128)(incl.Security Proxy), KNX Segment Coupler
- **Connectors:** Connector for KNX-TP main line (red/black), Connector for KNX-TP sub line (red/black)

### Dimensions (mm)

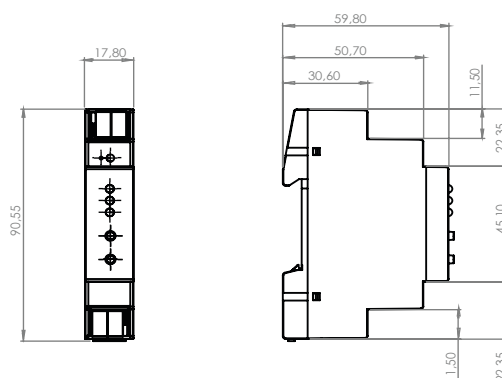

**Technical Information**

<b>Protection Type</b>	IP 20	EN 60529
<b>Safety Class</b>	III	IEC 61140
<b>Power Supply</b>	Voltage	21...30V DC, SELV
	Current Consumption (main)	< 5 mA
	Current Consumption (sub)	< 3 mA
<b>Connections</b>	KNX Line (main)	Bus connection terminal
	KNX Line (sub)	Bus connection terminal
<b>Operating Elements</b>	Function button, programming button, LEDs	
<b>Installation</b>	18mm DIN rail mount	EN 60715 TH 35-75
<b>Temperature Range</b>	Operation	-5° C + 45° C
	Storage	-25° C + 70° C
<b>Dimensions</b>	H x W x D	90 mm x W x 60 mm
	Width W in (mm)	18 mm
	Width W (unit)	1x18 mm modules
<b>Weight</b>	40 g	
<b>Box</b>	Housing: Plastic	
<b>CE</b>	In accordance with EMC and low voltage directives.	

**Ordering Information**

Product Name	Product Code	Ordering Code	Package Information
EAE KNX - Line Coupler Secure	SMP LC200S EAE S-KNX	50562	1 unit

# SWITCHES



## General Specifications

- Can be configured with ETS5 or higher.
- Glass, metal and plastic switch series.
- Wide range of colors (see: KNX Hotel, Residence and Smart Home Catalogue).
- Wide collection options;
  - Single to 6 fold for Oria Serie
  - Single to 5 fold for Rosa Metal and Crystal Series
  - 1 to 12 button for Mona Serie
- Product options with and without notification LED.
- Optionally, icon is available. / Temperature and Humidity sensor is available for Rosa and Oria
- Different color options (see: KNX Smart Home catalog).
- Easy installation to EU and BS backboxes.
- Channels are identical, each with the following functions;
  - Switching,
  - Dimming,
  - Shutter/Blind Control,
  - Value,
  - Scene Control,
  - Status notification LED

## Technical Information

<b>Protection Type</b>	IP 20	EN 60529
<b>Safety Class</b>	II	EN 61140
<b>Power Supply</b>	Bus voltage	21-30V DC, via KNX bus
	Current consumption (Mona)	<25 mA
	Current consumption (Rosa/Oria)	<10mA
<b>Connections</b>	EIB/KNX	Power Supply through EIB/KNX data line
<b>Operation LEDs</b>	Programming LED for each fold	To define physical address 1 to 5 RGB LED
<b>Button Operation Life</b>	100.000 (only Oria Series)	
<b>Operation Temperature</b>	Operation	-5° C + 45° C
	Storage	-25° C + 55° C
<b>CE</b>	Pursuant to EMC Guided and Low Voltage Regulation	

## Dimensions (mm)

**mona**

Type	a	b	h
Single	90	11	100

**rosa**

Type	a	b	h
Single	80	8,5	80
1 Fold	80	8,5	80
2 Fold	80	8,5	80
3 Fold	80	8,5	80
4 Fold	85	8,5	114
5 Fold	85	8,5	143

**oria**

Type	a	b	h
Single	90	9	90
1 Fold	90	9	90
2 Fold	90	9	90
3 Fold	90	9	90
4 Fold	90	9	90
5 Fold	90	9	111,5
6 Fold	90	9	133

# THERMOSTATS



## General Specifications

- Can be configured with ETS5 or higher
- Wide collection option up to 4 Folds
- Glass, metal and plastic thermostat series
- Temperature control via digital LCD
- Internal temperature sensor (°C/ °F)
- Adjustable fan speed (1, 2, 3, Automatic)
- Multiple operation modes (Comfort, Night, Out, Off)
- Fully automated operation feature (warm-cold transition)
- Control of all HVAC units including VRF-VRV and air conditioning devices
- PI proportional, PI on-off (PWM), On/Off, Fan coil, Split unit controls
- Easy installation to EU and BS backboxes
- Programmable buttons can be programmed for various functions. (2 dependent or 4 independent)
  - Switching,
  - Dimming,
  - Shutter/Blind Control,
  - Value,
  - Scene Control,
  - Status notification LED

## Technical Information

Protection Type	IP 20	EN 60529
Safety Class	II	EN 61140
Power Supply	Bus voltage	21-30V DC, via KNX bus
	Current consumption (Mona)	<25 mA
	Current consumption (Rosa/Oria)	<10 mA
Operation LEDs	Programming LED for each fold	To define physical address 1 to 5 RGB LED
Button Operation Life	100.000 (only Oria Series)	
Operation Temperature	Operation	-5° C + 45° C
	Storage	-25° C + 55° C
CE	Pursuant to EMC Guided and Low Voltage Regulation	

## Dimensions (mm)

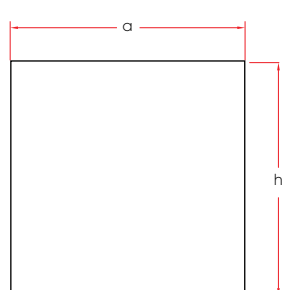

Type	a	b	h
Single	90	11	100



Type	a	b	h
1 Fold Thermostat	80	8,5	80
2 Fold Thermostat	80	8,5	80
3 Fold Thermostat	85	8,5	114
4 Fold Thermostat	85	8,5	143,60

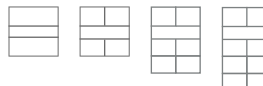

Type	a	b	h
2 Fold Thermostat	90	9	90
3 Fold Thermostat	90	9	111,5
4 Fold Thermostat	90	9	133

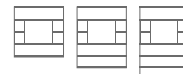

# CERTIFICATES

EAE Technology products are and will always be in compliance with international open standards such as KNX, DALI, TCP/IP and WiFi.



KNX is the worldwide standard for home and building control. KNX offers at the same time the reliability of a consolidated system, market leader for over twenty years. (470 KNX Members, 8000 Products, 470 KNX Training Centers, 83000 KNX Partners, 190 Countries)



DALI (Digital Addressable Lighting Interface) is a protocol for digital lighting control that enables the easy installation of robust, scalable and flexible lighting networks.



EU rules restricting the use of hazardous substances in electrical and electronic equipment to protect the environment and public health.



This standard is based on a number of quality management principles including a strong customer focus, the motivation and implication of top management, the process approach and continual improvement. These principles are explained in more detail in ISO's quality management principles.



The EAC certifications are issued by independent EAC certification bodies and their laboratories accredited by the relevant agencies of the five members of the EAC Economic Union: Russia, Belarus, Kazakhstan, Armenia and Kyrgyzstan.



# PANEL DEVICES

**RCU FAMILY**  
EAE KNX - ROOM CONTROL UNITS



**KMG103**  
EAE KNX - KNX Modbus Gateway



**KMG103 - AAZS**  
EAE KNX - KNX Modbus Gateway with Doorlock Integration



**UD106**  
EAE KNX - UNIVERSAL DIMMER



**SD110**  
EAE KNX - 1-10V DIM ACTUATOR



**FCA100**  
EAE KNX - FANCOIL ACTUATOR



**SW108 / SW104**  
EAE KNX - RELAY MODULE



**PSU320 / PSU640**  
EAE KNX - POWER SUPPLY 320mA/640mA



**MIO1616**  
EAE KNX - MULTI INPUT OUTPUT



**DA100 / DA110**  
EAE KNX - DALI GATEWAY



**UI108**  
EAE KNX - UNIVERSAL INTERFACE



**ACGME100**  
MITSUBISHI AC GATEWAY



**ACGDA100**  
DAIKIN AC GATEWAY



**IPR200 / IPI200 / IPR200S / IPI200S**  
EAE KNX - IP ROUTER - IP ROUTER SECURE  
IP INTERFACE - IP INTERFACE SECURE



**LC200 / LC200S**  
EAE KNX - LINE COUPLER -LINE COUPLER SECURE



## Sensors

**PD100 / MD100 / HB360 / CD100**  
EAE KNX - SENSOR



**HOTEL GRMS DEMO CASE**



**MONA DEMO BOX**



**ROSA DEMO BOX**



**ROSA DEMO CASE**





# SOME OF OUR REFERENCES



# GOVERNMENT/PUBLIC REFERENCES



**TURKISH AIRLINES OPERATION CENTER**  
Istanbul



**TURKISH DO&CO CATERING BUILDING**  
Istanbul



**TURKISH AIRLINES HANGARS**  
Istanbul



**IGA DATA CENTER**  
Istanbul



**TURKISH AIRLINES SIMULATION BUILDING**  
Istanbul



**ISTANBUL AIRPORT MOSQUE**  
Istanbul



**RIZE/ARTVIN AIRPORT**  
Rize



**TOKAT AIRPORT**  
Tokat



**KAYSERI AIRPORT**  
Kayseri



**7th MAIN JET BASE COMMAND**  
Malatya



**ANTALYA AIRPORT DIRECTORE**  
Antalya



**ANTALYA AIRPORT CARGO**  
Antalya



**DULKADIROGLU MUNICIPALITY**  
Kahramanmaras



**AKSARAY MUNICIPALITY**  
Aksaray



**GUNGOREN MUNICIPALITY BUILDING**  
Istanbul



**BAGCILAR MUNICIPALITY BUILDING**  
Istanbul

# GOVERNMENT/PUBLIC REFERENCES



ATATURK KULTUR MERKEZİ  
Istanbul



BAKIRKOY MUNICIPALITY  
Istanbul



SIVAS GOVERNORSHIP  
Sivas



SUPREME ELECTION BOARD  
Ankara



GENERAL DIRECTORATE OF  
HIGHWAYS  
Ankara



BURSA REGIONAL COURT OF  
JUSTICE  
Bursa



DUDULLU BOSTANCI  
TUNNELS  
Istanbul



TURKISH PUBLIC RAILWAYS  
Ankara



TURKIYE DIRECTORATE OF  
COMMUNICATIONS  
Ankara



ADIYAMAN GOVERNMENT  
HOUSE  
Adiyaman



GAZIANTEP TEACHERS'  
HOUSE  
Gaziantep



CANAKKALE MUNICIPAL  
BUILDING  
Canakkale



DENIZLI FORENSIC  
MEDICINE  
Denizli



IZMIR STATE HYDRAULIC  
WORKS  
Izmir



BEYOGLU SOCIAL SECURITY  
INSTITUTION BUILDING  
Istanbul



G.ANTEP SOCIAL SECURITY  
INSTITUTION BUILDING  
Gaziantep

# GOVERNMENT/PUBLIC REFERENCES



CUMHURBAŞKANLIĞI  
SENFONİ ORKESTRASI

PRESIDENTIAL SYMPHONY ORCHESTRA  
Ankara



ANTALYA CENTRAL BANK  
Antalya



ERDEMLİ COURTHOUSE  
Mersin



PRESIDENCY  
AHLAT COMPLEX  
Bitlis



AEGEAN CIVILIZATIONS  
MUSEUM  
Izmir



ADIYAMAN TEACHERS'  
HOUSE  
Adiyaman



GAZİANTEP  
GOVERNORSHIP  
Gaziantep



DISASTER and EMERGENCY  
MANAGEMENT CENTER  
Erzincan/Ankara/K.Maras



DISASTER and EMERGENCY  
MANAGEMENT CENTER  
Rize/Mugla/Kutahya



DISASTER and EMERGENCY  
MANAGEMENT CENTER  
Kastamonu/Burdur/Elazig



ANKARA DOCTORS' HOUSE  
Ankara



MERSİN SOCIAL SECURITY  
INSTITUTION BUILDING  
Mersin



ELAZIG SOCIAL SECURITY  
INSTITUTION BUILDING  
Elazig



KAYSERİ SOCIAL SECURITY  
INSTITUTION BUILDING  
Kayseri



DEDAS  
Diyarbakir



NATIONAL UNIVERSITY LIBRARY  
Istanbul

# HOSPITAL REFERENCES



REPUBLIC OF TÜRKİYE  
MINISTRY OF HEALTH

**KOCAELI CITY HOSPITAL**  
*Istanbul*



REPUBLIC OF TÜRKİYE  
MINISTRY OF HEALTH

**IZMIR CITY HOSPITAL**  
*Izmir*



REPUBLIC OF TÜRKİYE  
MINISTRY OF HEALTH

**KUTAHYA CITY HOSPITAL**  
*Kutahya*



REPUBLIC OF TÜRKİYE  
MINISTRY OF HEALTH

**ORDU CITY HOSPITAL**  
*Ordu*



REPUBLIC OF TÜRKİYE  
MINISTRY OF HEALTH

**GAZİANTEP MATERNITY HOSPITAL**  
*Gaziantep*



REPUBLIC OF TÜRKİYE  
MINISTRY OF HEALTH

**ERZINCAN 500 BED PUBLIC HOSPITAL**  
*Erzincan*



**ACIBADEM**

**ACIBADEM ATASEHIR HOSPITAL**  
*Istanbul*



**ACIBADEM**

**ACIBADEM ADANA HOSPITAL**  
*Adana*



**ACIBADEM**

**ACIBADEM IZMIR KENT HOSPITAL**  
*Izmir*



**ACIBADEM**

**ACIBADEM MALAYSIA HOSPITAL**  
*Malaysia*



**MEDICANA**

**MEDICANA IZMIR HOSPITAL**  
*Izmir*



REPUBLIC OF TÜRKİYE  
MINISTRY OF HEALTH

**TAKSİM İLK YARDIM HOSPITAL**  
*Istanbul*



REPUBLIC OF TÜRKİYE  
MINISTRY OF HEALTH

**KONYA NUMUNE HOSPITAL**  
*Konya*



REPUBLIC OF TÜRKİYE  
MINISTRY OF HEALTH

**MAMAK PUBLIC HOSPITAL**  
*Ankara*



REPUBLIC OF TÜRKİYE  
MINISTRY OF HEALTH

**SIVAS NUMUNE HOSPITAL**  
*Sivas*



REPUBLIC OF TÜRKİYE  
MINISTRY OF HEALTH

**ALGERIA HOSPITAL**  
*Algeria*

# HOSPITAL REFERENCES



REPUBLIC OF TÜRKİYE  
MINISTRY OF HEALTH

LUTFI KIRDAR TRAINING AND  
RESEARCH HOSPITAL  
*Istanbul*



REPUBLIC OF TÜRKİYE  
MINISTRY OF HEALTH

SAMSUN CITY HOSPITAL  
*Samsun*



REPUBLIC OF TÜRKİYE  
MINISTRY OF HEALTH

ERZURUM CITY HOSPITAL  
*Erzurum*



REPUBLIC OF TÜRKİYE  
MINISTRY OF HEALTH

KUTAHYA CITY HOSPITAL  
*Kutahya*



REPUBLIC OF TÜRKİYE  
MINISTRY OF HEALTH

MALATYA BATTALGAZI  
PUBLIC HOSPITAL  
*Malatya*



REPUBLIC OF TÜRKİYE  
MINISTRY OF HEALTH

BAGCILAR PUBLIC  
HOSPITAL  
*Istanbul*



REPUBLIC OF TÜRKİYE  
MINISTRY OF HEALTH

ESENYURT PUBLIC  
HOSPITAL  
*Istanbul*



REPUBLIC OF TÜRKİYE  
MINISTRY OF HEALTH

BARTIN PUBLIC HOSPITAL  
*Bartın*



REPUBLIC OF TÜRKİYE  
MINISTRY OF HEALTH

AGRI PUBLIC HOSPITAL  
*Agri*



REPUBLIC OF TÜRKİYE  
MINISTRY OF HEALTH

MERSIN TARSUS PUBLIC  
HOSPITAL  
*Mersin*



REPUBLIC OF TÜRKİYE  
MINISTRY OF HEALTH

GIRESUN KALE PUBLIC  
HOSPITAL  
*Giresun*



REPUBLIC OF TÜRKİYE  
MINISTRY OF HEALTH

NIGDE 400 BED PUBLIC  
HOSPITAL  
*Nigde*



REPUBLIC OF TÜRKİYE  
MINISTRY OF HEALTH

SAKARYA MATERNITY  
HOSPITAL  
*Sakarya*



REPUBLIC OF TÜRKİYE  
MINISTRY OF HEALTH

BOZUYUK PUBLIC  
HOSPITAL  
*Bilecik*



REPUBLIC OF TÜRKİYE  
MINISTRY OF HEALTH

HATAY DORTYOL PUBLIC  
HOSPITAL  
*Hatay*



REPUBLIC OF TÜRKİYE  
MINISTRY OF HEALTH

ADIYAMAN MATERNITY  
HOSPITAL  
*Adiyaman*

# SHOPPING MALL & SPORT FACILITY & SCHOOL REFERENCES



**IZMIR HILLTOWN SHOPPING MALL**  
Izmir



**NATA VEGA SUBAYEVLERI SHOPPING MALL**  
Ankara



**VEGA ISTANBUL SHOPPING MALL**  
Istanbul



**KOCTAS STORES**  
Istanbul



**LC WAIKIKI 500 STORES**  
Istanbul



**USKUDAR NEV SHOPPING MALL**  
Istanbul



**SENEGAL NATIONAL STADIUM**  
Senegal



**CEMAL KAMACI SPORT COMPLEX**  
Istanbul



**ERYAMAN STADIUM**  
Ankara



**RIVA GOLF CLUB**  
Istanbul



**ALSANCAK STADIUM**  
Izmir



**OZYEGIN UNIVERSITY**  
Istanbul



**ALTINBAS UNIVERSITY**  
Istanbul



**GONDAR UNIVERSITY**  
Ethiopia



**NECMETTİN ERBAKAN UNIVERSITY**  
Konya



**MEDENİYET UNIVERSITY LIBRARY & B / C BLOCK**  
Istanbul

# FACTORY REFERENCES



UNIPRES  
UK



BOSCH FACTORY  
Bursa



CAYKUR RIZE TEA FACTORY  
Rize



PHILIP MORRIS FACTORY  
Kazakhstan



KORDSA FACTORY  
Kocaeli



Mercedes-Benz  
MERCEDES BENZ TURKEY  
FACTORY  
Aksaray



ROKETSAN  
Ankara



MODERN PACKING  
Sakarya



SİŞECAM FACTORY  
Eskisehir/Ankara



TURK TRACTOR  
Sakarya



REPKN FACTORY  
Istanbul



ABDİBRAHİM



ABDI İBRAHİM  
Istanbul



TIRSAN  
Sakarya/Kocaeli



AKSA GENERATOR  
Istanbul



ARCELİK  
Manisa



BRISA  
Istanbul

# FACTORY REFERENCES



HYUNDAI ASSAN  
Kocaeli



CANDY HOOVER  
Eskisehir



COŞKUNOZ METAL  
Bursa



DURMAZLAR MACHINE  
Bursa



ISTANBUL PÜBLIC BREAD  
FACTORY  
Istanbul



ALVI MEDICA  
Istanbul



ASELSAN  
Ankara



TEI  
Eskisehir



HAKAN PLASTIC  
Cerkezoy



KOROZO  
Tekirdag



OTOKAR  
Sakarya



ASAS ALUMINUM  
Sakarya



NUROL MACHINE  
Ankara



NG CERAMIC FACTORY  
Kutahya



KUTAHYA CERAMIC  
FACTORY  
Kutahya



GURALLAR CERAMIC  
Kutahya



# OFFICE REFERENCES



BDDK  
Istanbul



ISTANBUL FINANCIAL  
CENTER HALK BANK GYO  
Istanbul



ISTANBUL FINANCIAL  
CENTER 1-13 RECREATION  
Istanbul



ISTANBUL FINANCIAL CENTER  
SPECIAL PROJECT AREA  
Istanbul



ISTANBUL FINANCIAL  
CENTER SIGORTA A.S.  
Istanbul



ISTANBUL FINANCIAL  
CENTER BORSA ISTANBUL  
Istanbul



ETI MADEN  
Ankara



ACIBADEM GENERAL  
CENTER  
Istanbul



MOIOSB  
Istanbul

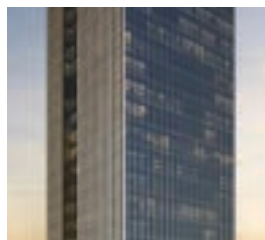

NOKIA TURKEY GENERAL  
CENTER  
Istanbul



BORSA ISTANBUL DATA  
CENTER  
Istanbul



TURKCELL DATA CENTER  
Ankara - Corlu - Gebze



KALYON HOLDING  
GENERAL CENTER  
Istanbul



KHOSHNAW TOWER  
Iraq



TECHNOPARK A BLOCK  
Istanbul



EGE YAPI GENERAL  
CENTER  
Istanbul

# OFFICE REFERENCES



HAVELSAN GENERAL CENTER  
Ankara



ILBANK ISTANBUL REGIONAL  
DIRECTORATE  
İstanbul



HUAWEI GENERAL  
CENTER  
İstanbul



Mercedes-Benz  
MERCEDES BENZ VADI  
İstanbul



TV100 GENERAL CENTER  
İstanbul



TURK TELEKOM UMRANIYE  
R&D BUILD  
İstanbul



YEDITEPE TECHNO PARK  
İstanbul



YDA CENTER  
Ankara



MARMARA ANATOLIUM  
TOWER  
İstanbul



IS GYO ANKARA TOWER  
Ankara



KARAT 34  
İstanbul



SARABSKI PLAZA  
Azerbaijan



OMSK CARBON OFFICE  
Russia



CBI BANK  
UAE



BAKU TOWER  
Azerbaijan



TOSYALI ADMINISTRATIVE  
BUILDING  
Hatay

# LOGISTIC CENTERS & PORTS REFERENCES



MILAHA LOGISTIC CITY  
Qatar



YALOVA RO-RO PORT  
Yalova



SAFI PORT  
Kocaeli



OYAKPORT YARIMCA  
Kocaeli



PTT INTERNATIONAL CARGO  
PROCESSING CENTER  
Istanbul



EKOL LOGISTIC  
Kocaeli



MIGROS WAREHOUSE  
Ankara



VITRA WAREHOUSE  
Bilecik



BIM & FILE WAREHOUSE  
Ankara



BORUSAN HOLDING  
LOJİSTİK WAREHOUSE  
Istanbul



LCW YALOVA WAREHOUSE  
Yalova



KAYSERI YATAS LOGISTIC  
Kayseri



MEDLOG LOGISTIC  
Izmir



AYDINLI LOGISTIC  
Istanbul



FY LOGISTIC  
Istanbul



TURKISH CARGO  
Istanbul

# RESIDENTIAL REFERENCES



## FOLKART VEGA

FOLKART VEGA  
İzmir



## FOLKART ÇEŞME

FOLKART BOYALIK  
İzmir



## nef

BODRUM NEF GOLKOY  
KEMPINSKI  
Bodrum



## ROUTE İSTANBUL

ROUTE İSTANBUL  
İstanbul



## Vadikoru

VADIKORU RESIDENCE  
İstanbul



## MESA CUBUKLU 28

MESA CUBUKLU 28  
İstanbul



## BONNEVILLE MİHRAPLI

BONNEVILLE MIHRAPLI  
Bursa



## CENTRAL BALAT

CENTRAL BALAT  
RESIDENCE  
Bursa



## ALTOWER

ALTOWER  
İstanbul



## BRODSKY

BRODSKY APARTMENT  
Russia



## MOTTO

MOTTO TERRACE GARDEN  
Konya



## BALANCE

BALANCE GÜNEŞLİ  
İstanbul



## COUNTRY SUIT

COUNTRY SUIT  
Gaziantep



## HESSAH AL MUBARAK

HESSAH AL MUBARAK  
Kuwait



## SPC BUILD

SPC BUILD  
Sapanca



## MERYAKA

MERYAKA RESIDENCE  
Konya

## RESIDENTIAL REFERENCES



MESA DEMIRBUKU  
Bodrum



MESA URLA  
Izmir



MESA ORMAN II  
Istanbul



MESA CENGELKÖY  
BOSPHORUS  
Istanbul



EMLAK KONUT ÇINARKÖY  
HOUSES  
Istanbul



KEMPINSKI RESIDENCE  
ALACATI  
Izmir



PARK PANORAMA  
Izmir



COS ALACATI  
Izmir



NOA TERRACE RESIDANCE  
Izmir



NISH MERAM  
Konya



PURA VIDA REZIDANCE  
Antalya



PUKKA MARE/NETA  
Bodrum



VERA BITEZ  
Bodrum



CLOUD NINE  
Russia



NAMET BEYLERBEYI  
Istanbul



SAKLIBAĞÇE  
SAKLIBAĞÇE CAMLICA  
Istanbul

# RESIDENTIAL REFERENCES



ARTAS EUROPEAN RESIDENCES /ATA BLOCKS  
Istanbul



**mona**  
ISTANBUL

MONA 94  
Istanbul



**FARAZGRUP**

NISH GUMUSLUK  
Bodrum



**MARITZA**  
INSAAT A.S.

MARITZA RESIDANCE  
Istanbul



MANDARIN VILLAS  
Çanakkale



**ALPER INŞAAT**

ARYA DELUXE  
Gaziantep



KECIOREN APARTMENTS  
Ankara



**naturapark meram**

NATURA PARK MERAM  
Konya



**ALI KEMAL GÜRDAL**  
INSAAT - YATIRIM - INOVASYON

A GARDENYA RESIDENCE  
Antalya



**DORUK**  
BeYTEPE

DORUK BEYTEPE  
Ankara



**ARMANI / CASA**  
MOSCOW RESIDENCES

ARMANI RESIDENCE  
Russia



**DorukPark**  
VILLALARI

DORUK PARK VILLAS  
Istanbul



**ROS**  
HEBİL

ROS HEBİL  
Bodrum



**KOMUT**  
Evleri

KOMUT HOUSES  
Konya



**OVOO**  
BODRUM

OVOO  
Bodrum



PARK ORMAN VILLAS  
Istanbul

# HOTEL REFERENCES



Le MERIDIEN MARRIOTT HOTEL  
Batumi



AUTOGRAPH COLLECTION MARRIOTT  
Istanbul



MARRIOTT SIRKECI HOTEL (Basiret Han)  
Istanbul



NG PHASELIS BAY HOTEL  
Antalya



MILLENNIUM WEST HOTEL  
Istanbul



RIXOS PREMIUM BODRUM  
Mugla



RADISSON HOTEL  
Izmir/Aliaga



RADISSON BLUE HOTEL  
India



MABIN HURA MALDIVES  
Maldives



RIXOS PREMIUM DUBAI  
UAE



GRAND HOTEL  
Niger



Türkiye Futbol Federasyonu  
Turkish Football Federation

TFF RIVA HOTEL  
Istanbul



NAU HOTEL  
Portugal

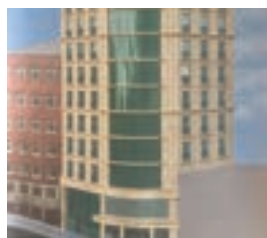

GRAND GALATA HOTEL  
Istanbul



KARAVANSARAY COMPLEX  
Kazakhstan



SHAHDAG HOTEL & SPA  
Azerbaijan

# HOTEL REFERENCES



SHERATON HOTEL BATUM  
Batumi



AKRA SORGUN TUI BLUE  
SENSORI  
Antalya



CROWNE PLAZA<sup>®</sup>  
HOTELS & RESORTS

CROWNE PLAZA  
ORYAPARK  
Istanbul



CROWNE PLAZA<sup>®</sup>  
HOTELS & RESORTS

CROWNE PLAZA  
TACHIKISTAN



RIXOS TEKIROVA  
Antalya



VONRESORT  
HOTELS  
VONRESORT KUŞADASI  
Antalya



DOLCE BY WYNDHAM  
Ankara



MELDEN HOTEL  
Mugla/Fethiye



SMART BY DEDEMAN  
HOTEL  
Eskisehir



WASHINGTON HOTEL  
Antalya



ROCKS HOTEL  
Cyprus



ALMIRA HOTEL  
BURSA  
Bursa



SHUSHA HOTEL  
Azerbaijan



DEMONTI HOTEL  
Ankara



TIERRA MAR HOTEL  
Antalya



LOV FARALYA  
Mugla



# HOTEL REFERENCES



Kempinski Hotel  
The Dome

BELEK ANTALYA

KEMPINSKI DOME BELEK  
Antalya



HAMPTON BY HILTON  
SIRKECI  
Istanbul



Hilton  
HOTELS & RESORTS

HILTON SARIKAMIS  
Kars



Hilton  
HOTELS & RESORTS

ALTUNIZADE HILTON  
Istanbul



INEMARE

İÇNEADA

INEMARE HOTEL  
Kırklareli



BENIN SOFITEL HOTEL  
Benin



FASQ HOTEL  
Mauritania



CIELO HOTEL  
Qatar



MÖVENPICK HOTEL  
UAE



ST REGIS

ST REGIS HOTEL  
Oman



ROTANA HOTEL  
UAE



EMILY RESORT  
Lviv



CONDOR HOTEL  
Romania



SHERATON HOTEL  
Senegal



PEARL MARRAKECH HOTEL  
Marrakech



KATE HOTEL SPECIAL CLASS  
Istanbul





*The information in this catalogue is subject to change without notice. Datasheet and user manuals should be consulted for the most accurate and up-to-date information.*

*EAE Technology assumes no responsibility for any errors that may appear in this document.*

2024 © EAE Technology  
All rights reserved





EAE Teknoloji A.Ş.  
İkitelli Organize Sanayi Bölgesi  
Eski Turgut Özal Caddesi No:20  
Başakşehir / İstanbul - TÜRKİYE  
Tel. : +90 212 413 21 00 (pbx)  
Fax : +90 212 549 37 90  
[www.eaetechnology.com](http://www.eaetechnology.com)



The information in this catalogue is subject to change without notice. Datasheet and user manuals should be consulted for the most accurate and up-to-date information.

EAE Technology does not accept any responsibility for out-of-date information that may appear in this document, due to the catalog version number 2024 © EAE Technology – All rights reserved  
ICBS - 202407 - 5003665 - V1.1